

# HYDROSTATIC STEERING UNIT TYPE HKU.../7



The HKU.../7 is a "Closed Center - Non Load Reaction" hydrostatic steering unit, designed for integration into systems with built-in hydroaccumulator, achieving minimal energy losses.

When connecting to a differential cylinder the L and R ports of the steering unit must be connected as follows: L to the greater piston area, and R - to the smaller one.

For the "Closed Center - Non Load Reaction" and "Closed Center - Non Reaction and Load Sensing" steering units is possible to observe Thermal Shock - condition caused when the hydraulic system has operated for some time without turning the steering wheel, causing the fluid in the reservoir and

the system to heat up while the steering unit is relatively cool (i.e. there is more than 500F [100C] difference in the temperature). If, under the condition of Thermal Shock, the steering wheel is turned very quickly, it is possible to experience temporary seizure and have the internal parts of the steering unit damaged. The temporary seizure may be followed by a total free wheeling.

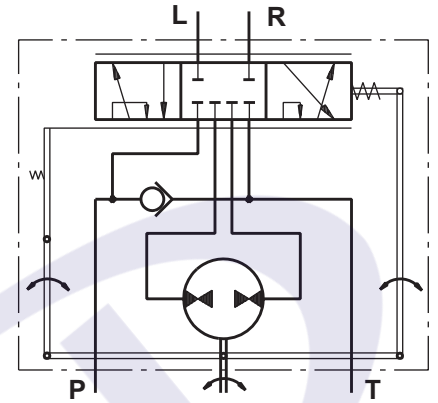

"Closed Center - Non Load Reaction"  
Version 7 - HKU.../7

## SPECIFICATION DATA

Parameters	Type															
	HKU 40/7	HKU 50/7	HKU 63/7	HKU 80/7	HKU 100/7	HKU 125/7	HKU 160/7	HKU 200/7	HKU 250/7	HKU 320/7	HKU 400/7	HKU 500/7	HKU 630/7	HKU 800/7		
Displacement	cm <sup>3</sup> /rev [in <sup>3</sup> /rev]	39,6 [2.42]	49,5 [3.0]	65,6 [4.0]	79,2 [4.83]	99,0 [6.04]	123,8 [7.56]	158,4 [9.67]	198 [12.1]	247,5 [15.1]	316,8 [19.3]	396 [24.2]	495 [30.2]	623,6 [38.05]	793 [48.4]	
Rated Flow*	lpm [GPM]	4 [1.1]	5 [1.3]	6 [1.6]	8 [2.1]	10 [2.6]	13 [3.4]	16 [4.2]	20 [5.3]	25 [6.6]	32 [8.4]	40 [10.6]	50 [13.2]	63 [16.6]	80 [21.1]	
Rated Pressure	bar [PSI]	125 [1810]	140 [2030]	175 [2540]												
Max. Cont. Pressure in Line T	bar [PSI]	-														
- standard		25 [363]														
- high pressure (H option)		40 [580]														
Max. Torque at Servoamplifying	Nm [lb-in]	-						3,0 [26]			3,0 [26]					
- with standard springs		-						3,0 [26]			-					
- with soft springs (LT option)		-						1,8 [16]			-					
Max. Torque w/o Servoamplifying	Nm [lb-in]	120 [1065]														
Weight	kg [lb]	5,3 [11.7]	5,4 [11.9]	5,5 [12.2]	5,6 [12.4]	5,7 [12.6]	5,8 [12.8]	6,0 [13.2]	6,3 [13.9]	6,5 [14.3]	7,0 [15.4]	7,4 [16.3]	8,0 [17.6]	8,7 [19.2]	9,6 [21.2]	
Dimension A	mm [in]	130,8 [5.15]	132,2 [5.20]	133,9 [5.27]	136,2 [5.36]	138,8 [5.47]	142,2 [5.60]	146,8 [5.78]	152,2 [5.99]	158,8 [6.25]	168,2 [6.62]	178,8 [7.04]	192 [7.56]	209,3 [8.24]	232,2 [9.14]	

\* Inlet flow providing maximum speed of rotation:

- 100 RPM - from HKU40 to HKU630;
- 87 RPM - for HKU800.

**DIMENSIONS AND MOUNTING DATA - HKU.../3, 4, 7**

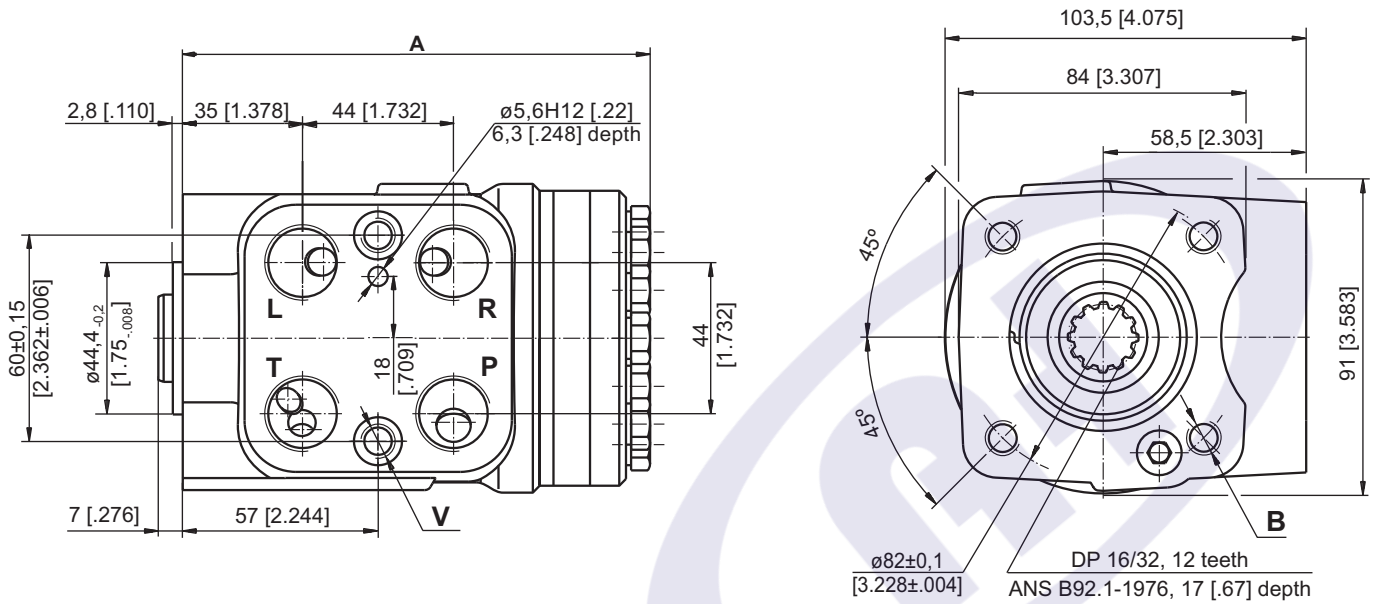

Code	Ports - P, T, R, L Thread	Column Mounting Thread - B	Valve Mounting Thread - V
-	G1/2 17 [.67] depth	4 x M10 18 [.71] depth	2 x M10x1 16 [.63] depth
M	M22x1,5 17 [.67] depth	4 x M10 18 [.71] depth	2 x M10x1 16 [.63] depth
A	3/4 - 16 UNF O-ring 17 [.67] depth	4 x 3/8 - 16 UNC 15,7 [.62] depth	2 x 3/8 - 24 UNF 14,2 [.56] depth
BA*	9/16 - 18 UNF O-ring 17 [.67] depth	4 x 3/8 - 16 UNC 15,7 [.62] depth	2 x 3/8 - 24 UNF 14,2 [.56] depth

\* These threads are for displacements from HKU40 to HKU200 only.

# HYDROSTATIC STEERING UNITS TYPE HKUS.../3, 4, 8



The HKUS Hydrostatic Steering unit is based on the HKU unit but has built-in relief and check valves. Thus M+S Hydraulic achieves one very compact steering unit which reduces the need for additional hydraulic components in the system.

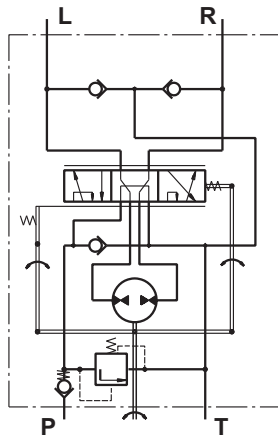

"Open Center - Load Reaction"  
HKUS.../3

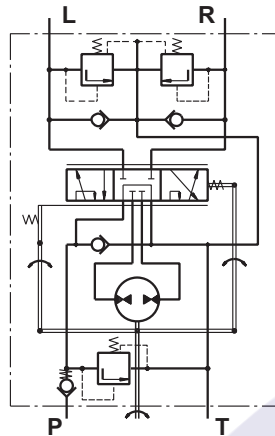

"Open Center - Non Load Reaction"  
HKUS.../4

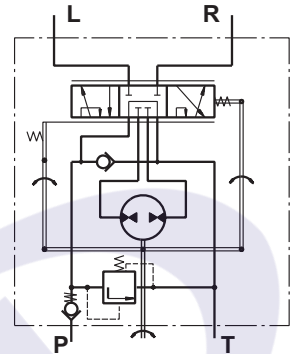

"Open Center - Non Load Reaction"  
HKUS.../8

## SPECIFICATION DATA

Parameters	Type												
	HKUS 40/3,4,8	HKUS 50/3,4,8	HKUS 63/3,4,8	HKUS 80/3,4,8	HKUS 100/3,4,8	HKUS 125/3,4,8	HKUS 160/3,4,8	HKUS 200/3,4,8	HKUS 250/3,4,8	HKUS 320/3,4,8	HKUS 400/3,4,8	HKUS 500/3,4,8	
Displacement	cm <sup>3</sup> /rev [in <sup>3</sup> /rev]	39,6 [2.42]	49,5 [3.0]	65,6 [4.0]	79,2 [4.83]	99,0 [6.04]	123,8 [7.56]	158,4 [9.67]	198 [12.1]	247,5 [15.1]	316,8 [19.3]	396 [24.2]	495 [30.2]
Rated Flow*	lpm [GPM]	4 [1.1]	5 [1.3]	6 [1.6]	8 [2.1]	10 [2.6]	13 [3.4]	16 [4.2]	20 [5.3]	25 [6.6]	32 [8.4]	40 [10.6]	50 [13.2]
Rated Pressure	bar [PSI]	140 [2030]		170 [2465]									
Relief Valve Pressure		80		100	125	150	170						
Settings**	bar [PSI]	[1160]		[1450]	[1810]	[2175]	[2465]						
Shock Valves Pressure		140		160	180	200	220						
Settings***	bar [PSI]	[2030]		[2320]	[2610]	[2900]	[3190]						
Max. Cont. Pressure in Line T	bar [PSI]	25 [363] (50 [725] by HKUS.../8)											
	- standard	40 [580]											
Max. Torque at Servoamplifying	Nm [lb-in]	3,0 [26]					3,0 [26]						
	- with standard springs	1,8 [16]					-						
	- with soft springs (LT option)												
Max. Torque w/o Servoamplifying	Nm [lb-in]	120 [1065]											
Weight	kg [lb]	5,3 [11.7]	5,4 [11.9]	5,5 [12.2]	5,6 [12.4]	5,7 [12.6]	5,8 [12.8]	6,0 [13.2]	6,3 [13.9]	6,5 [14.3]	7,0 [15.4]	7,4 [16.3]	8,0 [17.6]
Dimension A	mm [in]	130,8 [5.15]	132,2 [5.20]	133,9 [5.27]	136,2 [5.36]	138,8 [5.47]	142,2 [5.60]	146,8 [5.78]	152,2 [5.99]	158,8 [6.25]	168,2 [6.62]	178,8 [7.04]	192 [7.56]

\* Rated Flow at 100 RPM.

\*\* Pressure Settings are at Rated Flow (as in the table) and viscosity 21 mm<sup>2</sup>/s [105 SUS] at 50°C [122°F].

\*\*\* Pressure Settings are at flow rate of 2 lpm [.53 GPM] and viscosity 21 mm<sup>2</sup>/s [105 SUS] at 50°C [122°F].

**DIMENSIONS AND MOUNTING DATA - HKUS.../3, 4, 8**

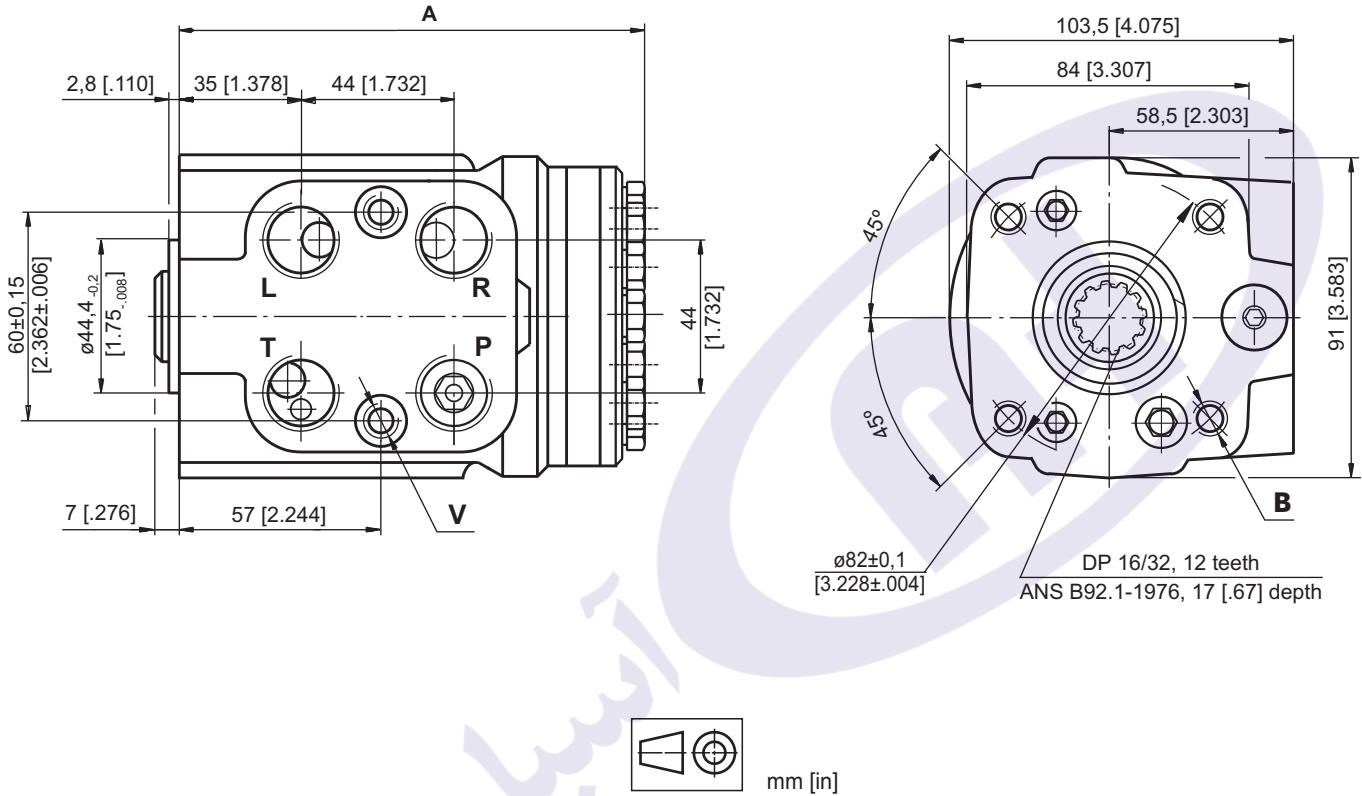

Code	Ports - P*, T, R, L Thread	Column Mounting Thread - B	Valve Mounting Thread - V
-	G1/2 17 [.67] depth	4 x M10 18 [.71] depth	2 x M10x1 16 [.63] depth
M	M22x1,5 17 [.67] depth	4 x M10 18 [.71] depth	2 x M10x1 16 [.63] depth
A	3/4 - 16 UNF O-ring 17 [.67] depth	4 x 3/8 - 16 UNC 15,7 [.62] depth	2 x 3/8 - 24 UNF 14,2 [.56] depth

\*Threaded Ports P min 15 [.59] depth for pipe mounting.

**STEERING  
UNITS**

**ORDER CODE**

	1	2	3	4	5	6	7	8
<b>HKU</b>		/	-					

**Pos.1 - Displacement code** (see Specification Data)

- 40** - 39,6 cm<sup>3</sup>/rev [2.42 in<sup>3</sup>/rev]
- 50** - 49,5 cm<sup>3</sup>/rev [3.00 in<sup>3</sup>/rev]
- 63** - 65,6 cm<sup>3</sup>/rev [4.00 in<sup>3</sup>/rev]
- 80** - 79,2 cm<sup>3</sup>/rev [4.83 in<sup>3</sup>/rev]
- 100** - 99,0 cm<sup>3</sup>/rev [6.04 in<sup>3</sup>/rev]
- 125** - 123,8 cm<sup>3</sup>/rev [7.56 in<sup>3</sup>/rev]
- 160** - 158,4 cm<sup>3</sup>/rev [9.67 in<sup>3</sup>/rev]
- 200** - 198,0 cm<sup>3</sup>/rev [12.10 in<sup>3</sup>/rev]
- 250** - 247,5 cm<sup>3</sup>/rev [15.10 in<sup>3</sup>/rev]
- 320** - 316,8 cm<sup>3</sup>/rev [19.30 in<sup>3</sup>/rev]
- 400** - 396,0 cm<sup>3</sup>/rev [24.20 in<sup>3</sup>/rev]
- 500** - 495,0 cm<sup>3</sup>/rev [30.20 in<sup>3</sup>/rev]
- 630** - 623,6 cm<sup>3</sup>/rev [38.05 in<sup>3</sup>/rev]
- 800** - 793,0 cm<sup>3</sup>/rev [48.40 in<sup>3</sup>/rev]
- 1000** - 990,0 cm<sup>3</sup>/rev [60.40 in<sup>3</sup>/rev]

**Pos.2 - Versions**

- 3** - Version 3 "Open Center - Load Reaction"
- 4** - Version 4 "Open Center - Non Load Reaction"
- 7** - Version 7 "Closed Center - Non Load Reaction"

**Pos.3 - Ports**

- omit - BSPP (ISO 228)
- M** - Metric (ISO 262)
- A** - SAE (ANSI B 1.1 - 1982)
- BA\*** - SAE (ANSI B 1.1 - 1982)

**Pos.4 - Max. Cont. Pressure in line T**

- omit - Standard
- H** - High pressure

**Pos.5 - Input torque**

- omit - Standard
- LT\*** - Low

**Pos.6 - Noise level**

- omit - Standard
- LN\*** - Low

**Pos.7 - Option (Paint)\*\*\***

- omit - No Paint
- P** - Painted
- PC** - Corrosion Protected Paint
- PS** - Special Paint\*\*\*\*
- PCS** - Special Corrosion Protected Paint\*\*\*\*

**Pos.8 - Design Series**

- omit - Factory specified

**Notes:**  
 \* Available only for displacement from 40 to 200.  
 \*\* Available only for versions 3 and 4 with displacement from 40 to 200.  
 \*\*\* Colour at customer's request.  
 \*\*\*\* Non painted feeding surfaces, colour at customer's request.

The steering units are mangano-phosphatized as standard.

**ORDER CODE**

	1	2	3	4	5	6	7	8	9
<b>HKUS</b>		/	-	-					

**Pos.1 - Displacement code** (see Specification Data)

- 40** - 39,6 cm<sup>3</sup>/rev [2.42 in<sup>3</sup>/rev]
- 50** - 49,5 cm<sup>3</sup>/rev [3.00 in<sup>3</sup>/rev]
- 63** - 65,6 cm<sup>3</sup>/rev [4.00 in<sup>3</sup>/rev]
- 80** - 79,2 cm<sup>3</sup>/rev [4.83 in<sup>3</sup>/rev]
- 100** - 99,0 cm<sup>3</sup>/rev [6.04 in<sup>3</sup>/rev]
- 125** - 123,8 cm<sup>3</sup>/rev [7.56 in<sup>3</sup>/rev]
- 160** - 158,4 cm<sup>3</sup>/rev [9.67 in<sup>3</sup>/rev]
- 200** - 198,0 cm<sup>3</sup>/rev [12.10 in<sup>3</sup>/rev]
- 250** - 247,5 cm<sup>3</sup>/rev [15.10 in<sup>3</sup>/rev]
- 320** - 316,8 cm<sup>3</sup>/rev [19.30 in<sup>3</sup>/rev]
- 400** - 396,0 cm<sup>3</sup>/rev [24.20 in<sup>3</sup>/rev]
- 500** - 495,0 cm<sup>3</sup>/rev [30.20 in<sup>3</sup>/rev]

**Pos.2 - Versions**

- 3** - Version 3 "Open Center - Load Reaction"
- 4** - Version 4 "Open Center - Non Load Reaction"
- 8** - Version 8 "Open Center - Non Load Reaction"

**Pos.3 - Relief Valve Pressure Settings, bar**

**80, 100, 125, 150, 170**

**Pos.4 - Ports**

- omit - BSPP (ISO 228)
- A** - SAE (ANSI B 1.1 - 1982)
- M** - Metric (ISO 262)

**Pos.5 - Max. Cont. Pressure in line T**

- omit - Standard
- H** - High pressure

**Pos.6 - Input torque**

- omit - Standard
- LT\*** - Low

**Pos.7 - Noise level**

- omit - Standard
- LN\*** - Low

**Pos.8 - Option (Paint)\*\*\***

- omit - No Paint
- P** - Painted
- PC** - Corrosion Protected Paint
- PS** - Special Paint\*\*\*\*
- PCS** - Special Corrosion Protected Paint\*\*\*\*

**Pos.9 - Design Series**

- omit - Factory specified

Version	Manual Steering Check Valve	Relief Valve	Inlet Check Valve	Cylinder Relief Valve	Anti-Cavitation Valve
3	•	•	•		•
4	•	•	•	•	•
8	•	•	•		

**Notes:**  
 \* Available only for displacement from 40 to 200.  
 \*\* Colour at customer's request.  
 \*\*\* Non painted feeding surfaces, colour at customer's request.

The steering units are mangano-phosphatized as standard.