

HYDROSTATIC STEERING UNITS TYPE HKU(S).../5(D)(T)(E)(TE)(TU)-



The HKU(S).../5(D)(T)(TU) range expands the steering units family of M+S Hydraulic with the "Closed Center - Non Reaction and Load Sensing Outlet" version (static and dynamic hydraulic connection to the priority valve).

This range is manufactured in two versions; for modularly and pipe mounting and therefore were developed the two versions of priority (tracing) valves: PRD... and PRT...

HKU.../5 is designed to be connected to priority valves with built-in relief valves for rated flow up to 160 lpm [42 GPM] - PRT.../160.

The control hydraulic circuits of the HKU(S).../5(T) steering units were designed to ensure minimal energy consumption (energy losses) in various hydraulic systems, such as those of: fork-lift trucks, agricultural and construction machines and others.

HKU.../5TU is a steering unit at which the ports R and L in neutral position are connected to the drain line T. This scheme contributes for the fast discharge of the residual pressure in lines L and R, that usually is "locked" when the steering wheel is jerky released at neutral position. These steering units do not drive directly the steering cylinders, but they are connected to hydraulic systems in which they drive the flow amplifiers or other devices.

M+S Hydraulic produces steering units type HKUS.../5E(5TE) which have additional EL-port. An electro-hydraulic relay can be mounted on this port, providing control of the hydraulic system. The relay can be pre-set to normally - open (N.O) or normally - closed (N.C) contacts, with control range from 0,1 to 50 bars.

HKUS.../5D(DT)... is a new generation steering unit, where the dynamic flow to LS-line allows easy and smooth control when starting the steering. Main features are: Low torque of the steering wheel 0,5÷2,0 Nm [4.5÷18 lb-in] at normal operating conditions; High steering speed, limited only by the operating flow and the pressure of the supplying pump.

Constant oil flow to LS-line at neutral position within 0,45÷0,9 lpm [.12÷.24 GPM]. The unit works in a system with a dynamic priority valve and is appropriate for machines with increased energy saving requirements.

*For operation in condition of Thermal Shock see the notes on page 6.

Pipe Mounting

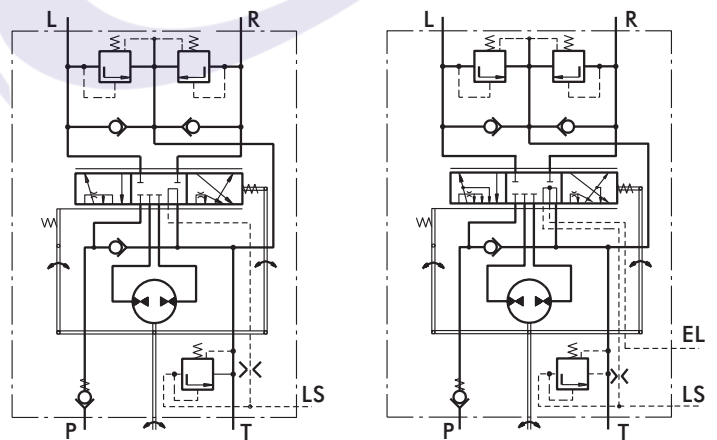

Closed Center - Non Reaction
Static Signal - HKUS.../5T
Dynamic Signal - HKUS.../5DT

Closed Center - Non Reaction
Static Signal - HKUS.../5TE

Modularity Mounting

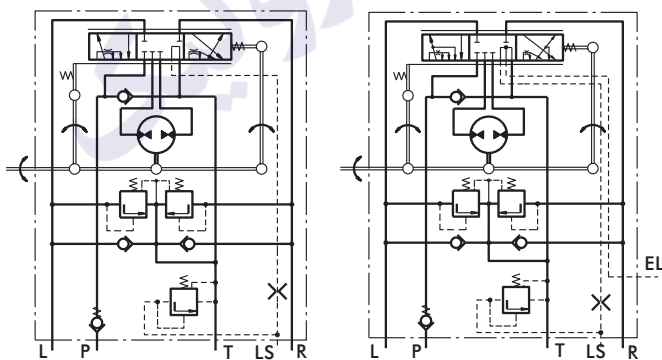

Closed Center - Non Reaction
Static Signal - HKUS.../5
Dynamic Signal - HKUS.../5D

Closed Center - Non Reaction
Static Signal - HKUS.../5E

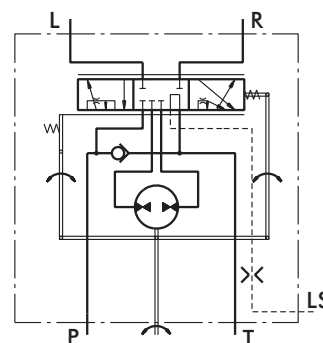

Closed Center - Non Reaction
Static Signal - HKU.../5T

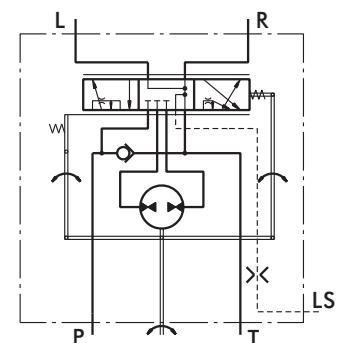

Closed Center - Non Reaction
Static Signal - HKU.../5TU

SPECIFICATION DATA

Parameters		Type												
		HKU 40/5T	HKU 50/5T	HKU 63/5T	HKU 80/5T	HKU 100/5T	HKU 125/5T	HKU 160/5T	HKU 200/5T	HKU 250/5T	HKU 320/5T	HKU 400/5T	HKU 500/5T	HKU 630/5T
		HKUS 40/5...	HKUS 50/5...	HKUS 63/5...	HKUS 80/5...	HKUS 100/5...	HKUS 125/5...	HKUS 160/5...	HKUS 200/5...	HKUS 250/5...	HKUS 320/5...	HKUS 400/5...		
Displacement	cm ³ /rev [in ³ /rev]	39,6 [2.42]	49,5 [3.0]	65,6 [4.0]	79,2 [4.83]	99,0 [6.04]	123,8 [7.56]	158,4 [9.67]	198 [12.1]	247,5 [15.1]	316,8 [19.3]	396 [24.2]	495 [30.2]	623,6 [38.05]
Rated Flow*	lpm [GPM]	4 [1.1]	5 [1.3]	6 [1.6]	8 [2.1]	10 [2.6]	13 [3.4]	16 [4.2]	20 [5.3]	25 [6.6]	32 [8.4]	40 [10.6]	50 [13.2]	63 [16.6]
Rated Pressure	bar [PSI]	125 [1810]	150 [2175]	175 [2540]										
LS-Valve Pressure Settings**	bar [PSI]				80 [1160]	100 [1450]	125 [1810]	150 [2175]	175 [2540]					
Shock Valves Pressure Settings***	bar [PSI]				140 [2030]	160 [2320]	180 [2610]	200 [2900]	240 [3480]					
Max. Cont. Pressure in Line T	bar [PSI]							20 [290]	40 [580]					
Max. Torque at Servoamplifying	Nm [lb-in]							3,0 [26]	1,8 [16]					
-with standard springs										3,0 [26]				
-with soft springs (LT option)														
Max. Torque w/o Servoamplifying	Nm [lb-in]	120 [1065]												
Weight	kg [lb]	5,3 [11.7]	5,4 [11.9]	5,5 [12.2]	5,6 [12.4]	5,7 [12.6]	5,8 [12.8]	6,0 [13.2]	6,3 [13.9]	6,5 [14.3]	7,0 [15.4]	7,4 [16.3]	8,0 [17.6]	8,7 [19.2]
Dimension A	mm [in]	130,8 [5.15]	132,2 [5.20]	133,9 [5.27]	136,2 [5.36]	138,8 [5.47]	142,2 [5.60]	146,8 [5.78]	152,2 [5.99]	158,8 [6.25]	168,2 [6.62]	178,8 [7.04]	192 [7.56]	209,3 [8.24]

* Rated Flow at 100 RPM.

** Pressure Settings are at flow rate of 25 lpm [6.6 GPM] and viscosity 21 mm²/s [105 SUS] at 50° C [122°F], supplied through priority valve.

*** Pressure Settings are at flow rate of 2 lpm [.53 GPM] and viscosity 21 mm²/s [105 SUS] at 50° C [122°F].

DIMENSIONS AND MOUNTING DATA - HKU.../5T(TU)

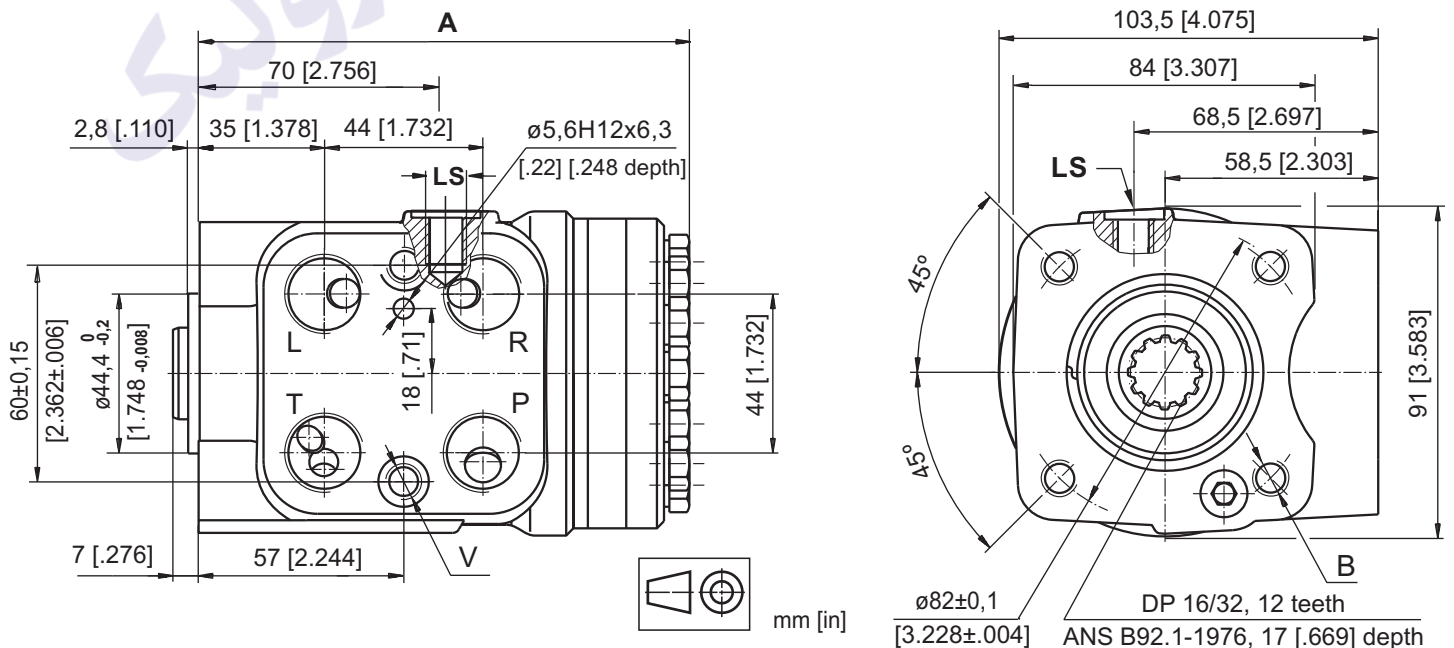

DIMENSIONS AND MOUNTING DATA - HKUS.../5(D)

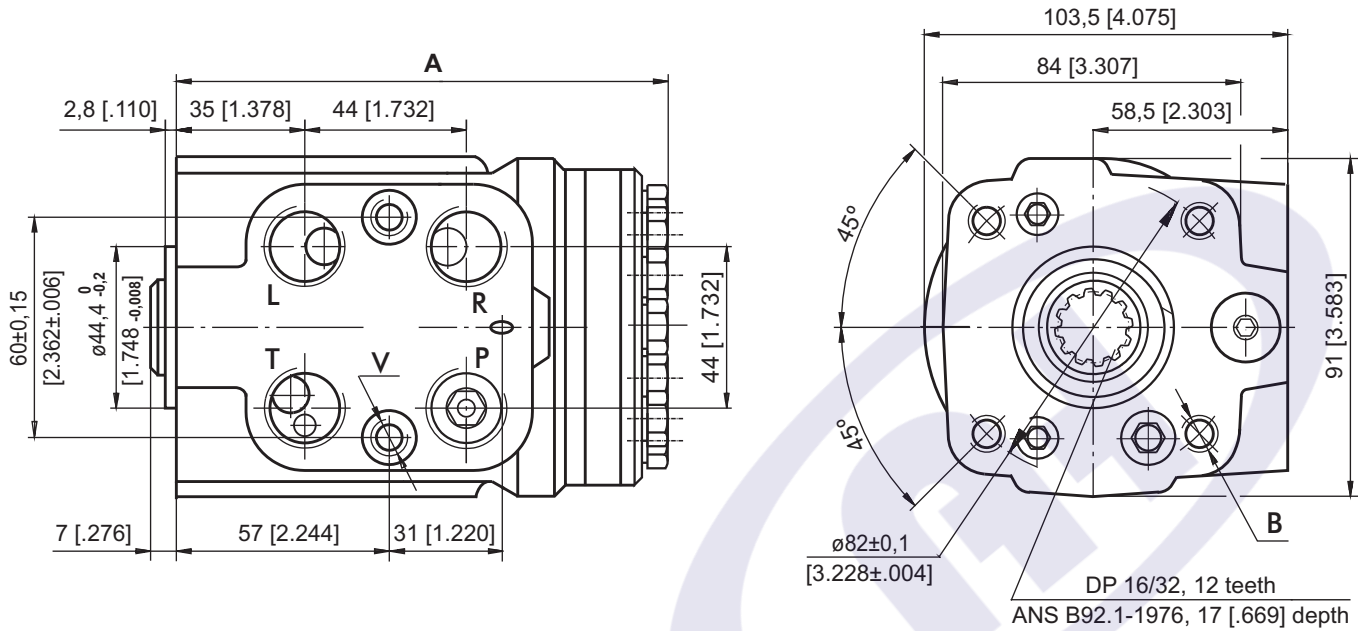

DIMENSIONS AND MOUNTING DATA - HKUS.../5T(DT)

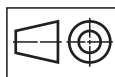
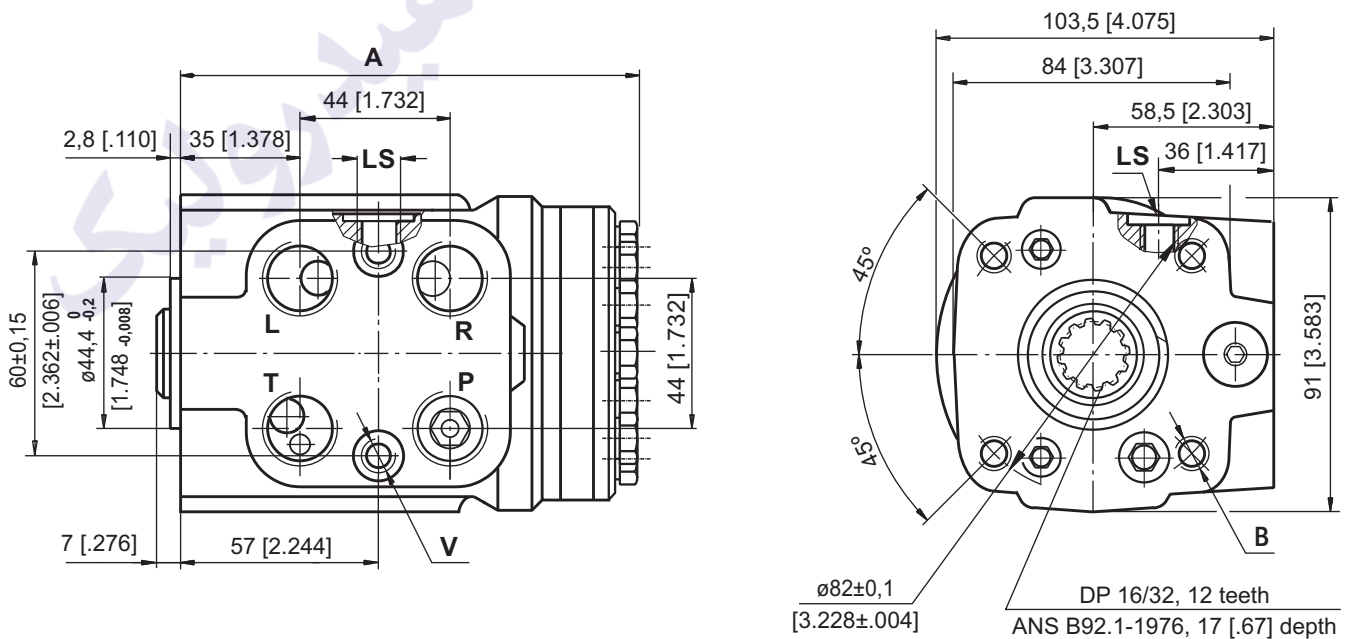

mm [in]

The ports are shown in the Table on page 20.

DIMENSIONS AND MOUNTING DATA - HKUS.../5E

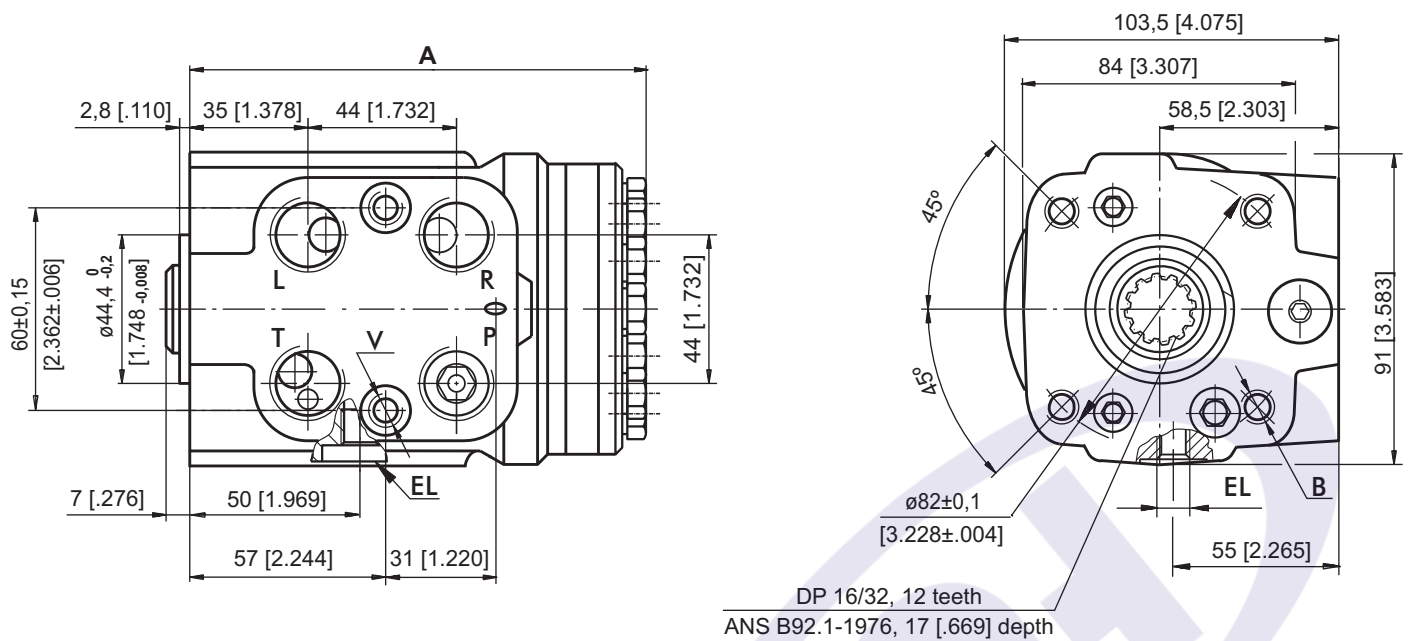

DIMENSIONS AND MOUNTING DATA - HKUS.../5TE

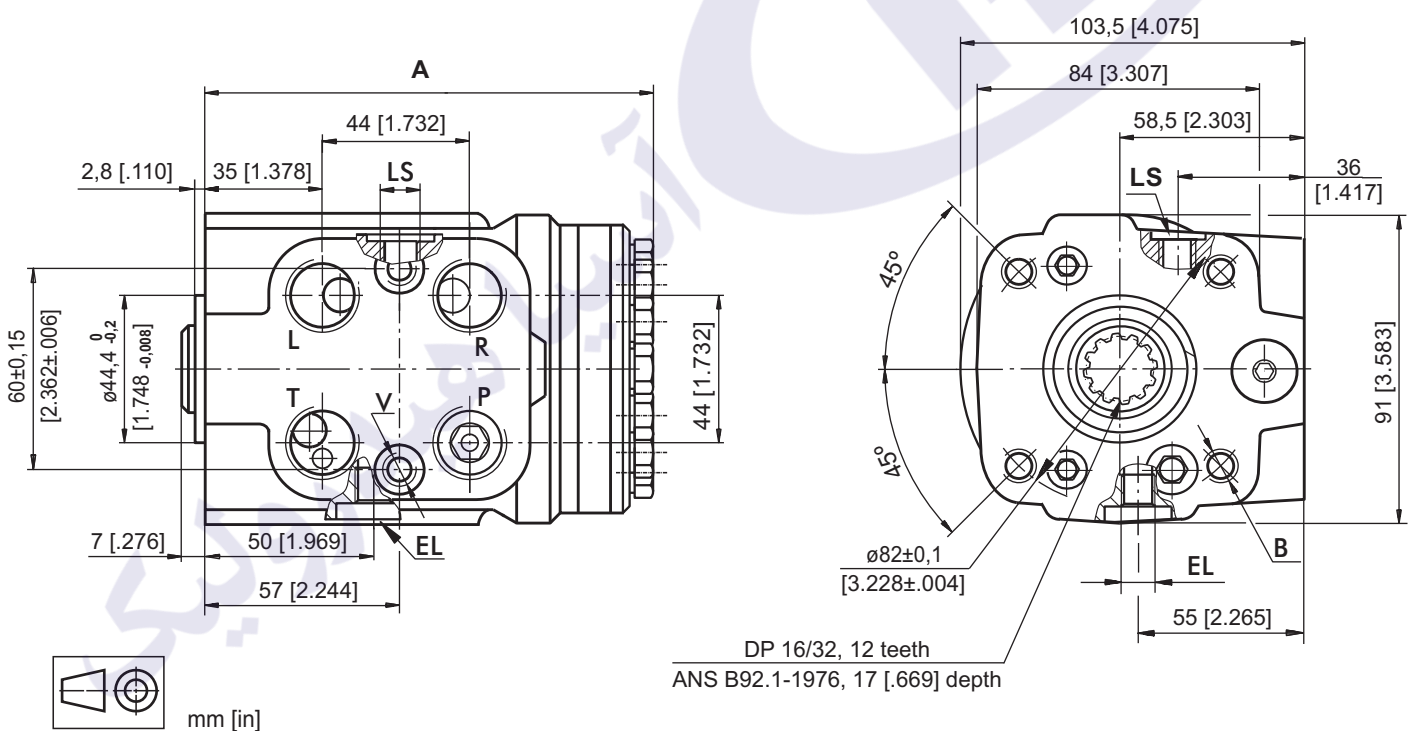

Code	Ports - P*, T, R, L Thread	Column Mounting Thread - B	Valve Mounting Thread - V	LS - Port	EL - Port
-	G1/2 17 [.67] depth	4 x M10 18 [.71] depth	2 x M10x1 16 [.63] depth	G1/4 14 [.55] depth	M10x1 10 [.39] depth
M	M22x1,5 17 [.67] depth	4 x M10 18 [.71] depth	2 x M10x1 16 [.63] depth	G1/4 14 [.55] depth	M10x1 10 [.39] depth
A	3/4 - 16 UNF O-ring 17 [.67] depth	4 x 3/8 - 16 UNC 15,7 [.62] depth	2 x 3/8 - 24 UNF 14,2 [.56] depth	7/16 - 20 UNF O-ring 12,7 [.50] depth	7/16 - 20 UNF O-ring 12,7 [.50] depth

*Threaded Ports P min 15 [.59] depth for pipe mounting.

**STEERING
UNITS**

ORDER CODE for HKUS.../5...

1	2	3	4	5	6	7	8	9	10	11
HKUS	/	5			-					

Pos.1 - Displacement code (see Specification Data)

40	- 39,6 cm ³ /rev [2.42 in ³ /rev]
50	- 49,5 cm ³ /rev [3.00 in ³ /rev]
63	- 65,6 cm ³ /rev [4.00 in ³ /rev]
80	- 79,2 cm ³ /rev [4.83 in ³ /rev]
100	- 99,0 cm ³ /rev [6.04 in ³ /rev]
125	- 123,8 cm ³ /rev [7.56 in ³ /rev]
160	- 158,4 cm ³ /rev [9.67 in ³ /rev]
200	- 198,0 cm ³ /rev [12.10 in ³ /rev]
250	- 247,5 cm ³ /rev [15.10 in ³ /rev]
320	- 316,8 cm ³ /rev [19.30 in ³ /rev]
400	- 396,0 cm ³ /rev [24.20 in ³ /rev]

Pos.2 - Versions

5	- Version 5 "Closed Center - Non Reaction and Load Sensing Outlet"
---	--

Pos.3 - Signal Type

omit	- Static Load Signal
D	- Dynamic Load Signal

Pos.4 - Priority Valve Connection

omit	- Modulary Mounting
T	- Pipe Mounting

Pos.5 - Electric Signal Connection

omit	- Without electric signal connection
E	- With electric signal connection*

Pos.6 - LS - Valve Pressure Settings, bar

80	100	125	150	175
----	-----	-----	-----	-----

Pos.7 - Ports

omit	- BSPP (ISO 228)
M	- Metric (ISO 262)
A	- SAE (ANSI B 1.1 - 1982)

Pos.8 - Max. Cont. Pressure in line T

omit	- Standard
H	- High pressure

Pos.9 - Input torque

omit	- Standard
LT**	- Low

Pos.10 - Option (Paint)***

omit	- No Paint
P	- Painted****
PC	- Corrosion Protected Paint*****
PS	- Special Paint*****
PCS	- Special Corrosion Protected Paint*****

Pos.11 - Design Series

omit	- Factory specified
------	---------------------

Notes:

- * Available with Static Load Signal only.
 - ** Available for displacement from 40 to 200 only.
 - *** Colour at customer's request.
 - **** Not for HKUS.../5 and HKUS.../5D.
 - ***** Non painted feeding surfaces, colour at customer's request.
- The steering units are mangano-phosphatized as standard.

ORDER CODE for HKU.../5T...

1	2	3	4	5	6	7	8
HKU	/	5		-			

Pos.1 - Displacement code (see Specification Data)

40	- 39,6 cm ³ /rev [2.42 in ³ /rev]
50	- 49,5 cm ³ /rev [3.00 in ³ /rev]
63	- 65,6 cm ³ /rev [4.00 in ³ /rev]
80	- 79,2 cm ³ /rev [4.83 in ³ /rev]
100	- 99,0 cm ³ /rev [6.04 in ³ /rev]
125	- 123,8 cm ³ /rev [7.56 in ³ /rev]
160	- 158,4 cm ³ /rev [9.67 in ³ /rev]
200	- 198,0 cm ³ /rev [12.10 in ³ /rev]
250	- 247,5 cm ³ /rev [15.10 in ³ /rev]
320	- 316,8 cm ³ /rev [19.30 in ³ /rev]
400	- 396,0 cm ³ /rev [24.20 in ³ /rev]
500	- 495,0 cm ³ /rev [30.20 in ³ /rev]
630	- 623,6 cm ³ /rev [38.05 in ³ /rev]

Pos.2 - Versions

5	- Version 5 "Closed Center - Non Reaction and Load Sensing Outlet"
---	--

Pos.3 - Priority Valve Connection

T	- Pipe Mounting (only)
TU	- Pipe Mounting (ports R and L in neutral position are connected to the drain line T)

Pos.4 - Ports

omit	- BSPP (ISO 228)
M	- Metric (ISO 262)
A	- SAE (ANSI B 1.1 - 1982)

Pos.5 - Max. Cont. Pressure in line T

omit	- Standard
H	- High pressure

Pos.6 - Input torque

omit	- Standard
LT*	- Low

Pos.7 - Option (Paint)**

omit	- No Paint
P	- Painted
PC	- Corrosion Protected Paint
PS	- Special Paint***
PCS	- Special Corrosion Protected Paint***

Pos.8 - Design Series

omit	- Factory specified
------	---------------------

Notes:

- * Available only for displacement from 40 to 200.
 - ** Colour at customer's request.
 - *** Non painted feeding surfaces, colour at customer's request.
- The steering units are mangano-phosphatized as standard.