

HYDRAULIC DISC BRAKES LB, LBS, LBV - wet



APPLICATION

- Heavy Duty machinery
- Wheel drives
- Material handling
- Mining
- Agricultural machines
- Conveyors
- Door openers and swing drives etc.



GENERAL

Fluid type	Mineral based- HLP(DIN 51524) or HM(ISO 6743/4)
Temperature range, °C [°F]	-40÷140 [-40÷284]
Viscosity range, mm²/s	20÷75 [98÷347]
Filtration	ISO code 20/16 (nominal filtration of 25 microns)
Maintenance	Changed after the first 50-100 h, then after every 500-1500 h.

CONTENTS

Hydraulic Disc Brake for MP, MR and MS Motors type LB/288	4+5
Hydraulic Disc Brake for MSS and MSV type LBS(V)/289	6
Hydraulic Disc Brake for MSS and MSV type LBS(V)/290	7
Output Shafts for LBS(LBV)/289, 290	8
Specification data for LBS(LBV)/289, 290	8
Load curve for LBS(LBV)/289, 290	8
Internal Spline data for .../289,290 and .../314,315.....	9
Order code for LB/288,LBS(LBV)/289, 290	9
Hydraulic Disc Brake for MTS and MTV type LBS(LBV)/314	10
Hydraulic Disc Brake for MTS and MTV type LBS(LBV)/315	11
Specification data for LBS(LBV)/314, 315	12
Load curve for LBS(LBV)/314, 315	12
Output Shafts for LBS(LBV)/314, 315	13
Order code for LBS(LBV)/314, 315	13
Hydraulic Disc Brake for MVS type LBS/313	14
Load curve for LBS/313	14
Hydraulic Disc Brake for MVS type LBS/316	15
Load curve for LBS/316	15
Specification data for LBS/313, 316.....	16
Output Shafts for LBS/313, 316	16
Internal Spline data for LBS/313, 316	17
Order code for LBS/313, 316	17

LB, LBS

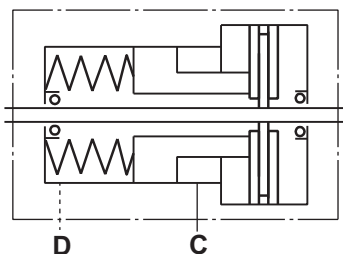

LBV

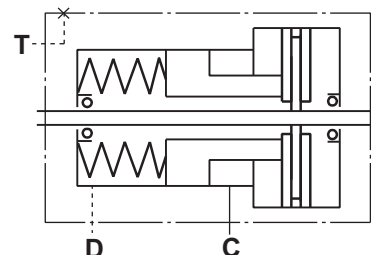

HYDRAULIC DISC BRAKE FOR FLANGE ATTACHMENT TO MP, MR AND MS HYDRAULIC MOTORS

TYPE LB/288

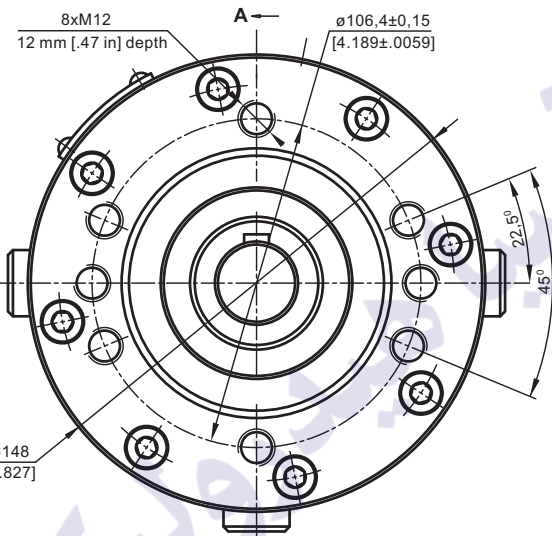
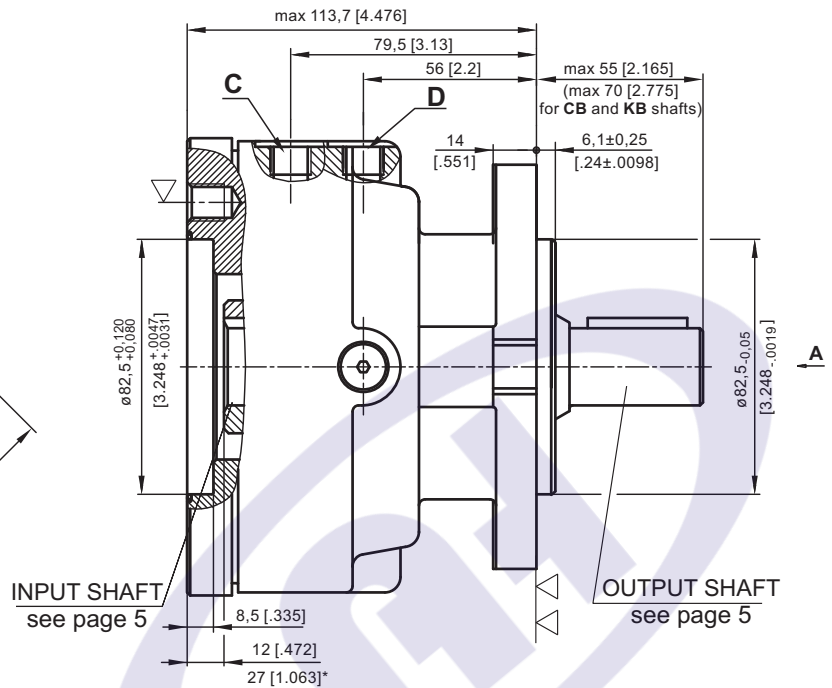
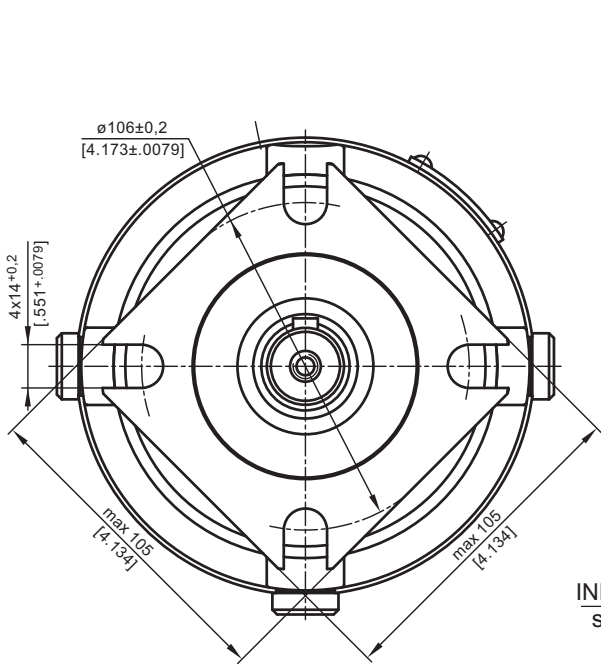

▽ - Place for attachment (tightening torque for screw M12x30 - 8.8 DIN 912 - 7 daNm [620 lb-in])

▽▽ - Place for attachment

C: Brake release Port - G $\frac{1}{4}$, 9 mm [0.35 in] depth
D: Drainage tap - G $\frac{1}{4}$, 9 mm [0.35 in] depth

* - For Input Shaft Hole Versions **SH** and **SB**.

LOAD CURVE

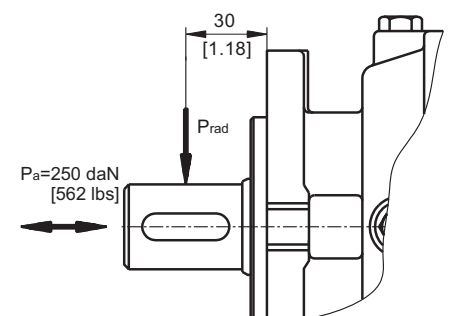
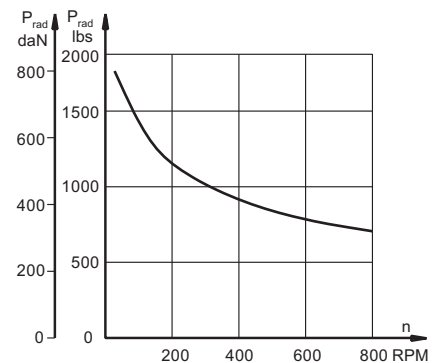

SPECIFICATION DATA

Description LB/288...	7	14	21	32	43	63
*Min. Static Torque, daNm [lb-in]	6-8 [531-708]	13-15 [1150-1327]	20-22 [1770-1947]	31-34 [2743-3009]	41-45 [3628-3982]	61-64 [5399-5665]
Opening Pressure, min bar [PSI]	4-5 [58-73]	8-9 [116-130]	12-13 [174-188]	18-20 [260-290]	24-26 [348-377]	38-39 [550-565]
max	300 [4350]					
Min. oil quantity for brake releasing, cm ³ [in ³]	7 - 8 [0.427 - 0.488]					
Oil volume, cm ³ [in ³]	50 - 120 [3.5 - 7.35]					
Max. Pressure in drain space, bar [PSI]	0,5 [7.25]					
Weight, kg [lb]	9 [19.8]					

*Static torque is obtained at working pressure - 0 bar [0 PSI].

INPUT SHAFT HOLES

OUTPUT SHAFT EXTENSIONS

C

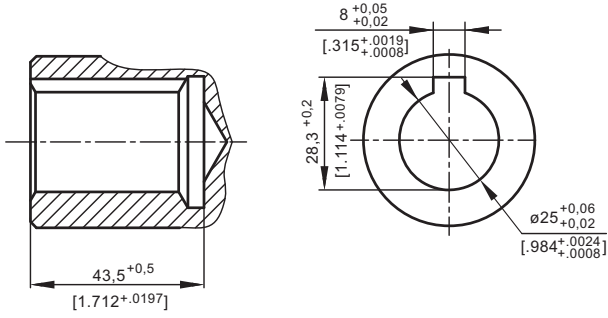

CO

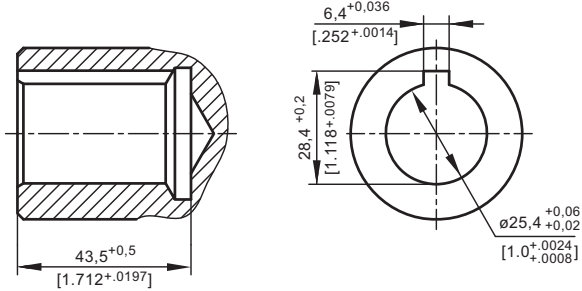

SH

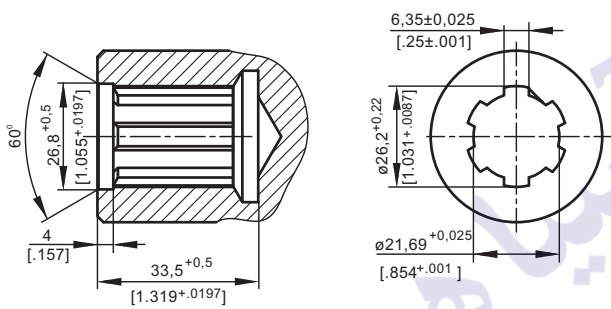

SB

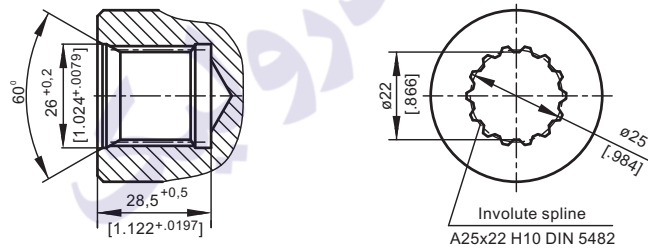

CB

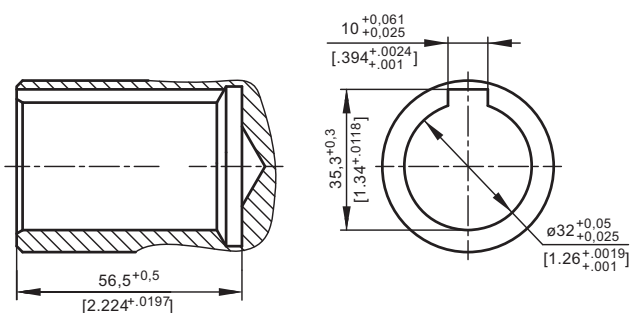

C - $\phi 25$ straight, Parallel key A8x7x32 DIN 6885
Max. Torque 34 daNm [3010 lb-in]

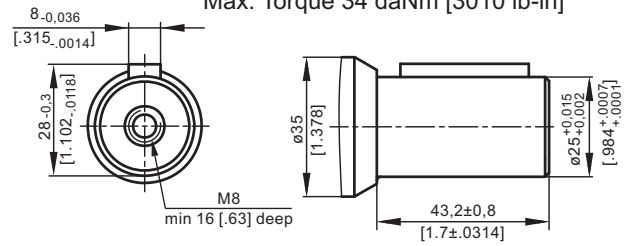

CO - $\phi 1"$ straight, Parallel key $\frac{1}{4}" \times \frac{1}{4}" \times \frac{1}{4}"$ BS46
Max. Torque 34 daNm [3010 lb-in]

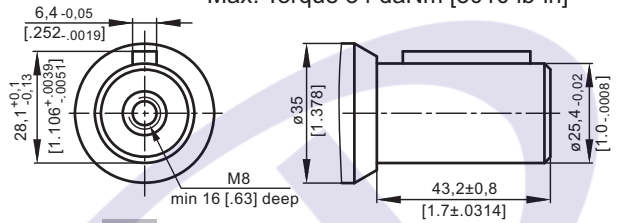

SH - splined, BS 2059 (SAE 6B)
Max. Torque 40 daNm [3540 lb-in]

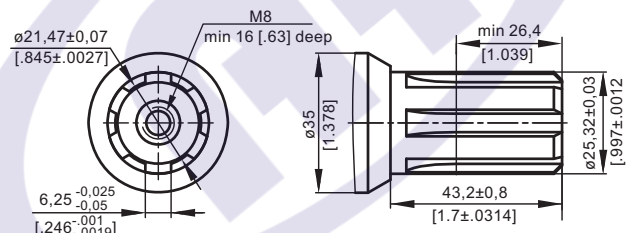

SA - splined, B25x22h9 DIN 5482
Max. Torque 40 daNm [3540 lb-in]

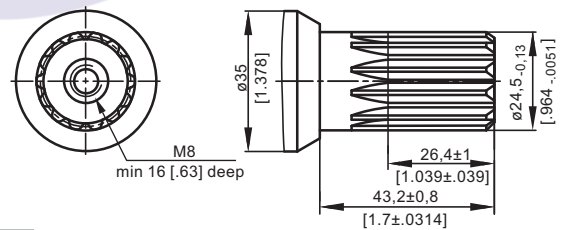

CB - $\phi 32$ straight, Parallel key A10x8x45 DIN 6885
Max. Torque 77 daNm [6815 lb-in]

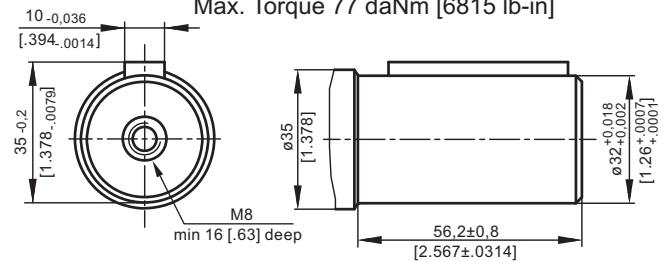

KB - tapered 1:10, Parallel key B6x6x20 DIN 6885
Max. Torque 95 daNm [8400 lb-in]

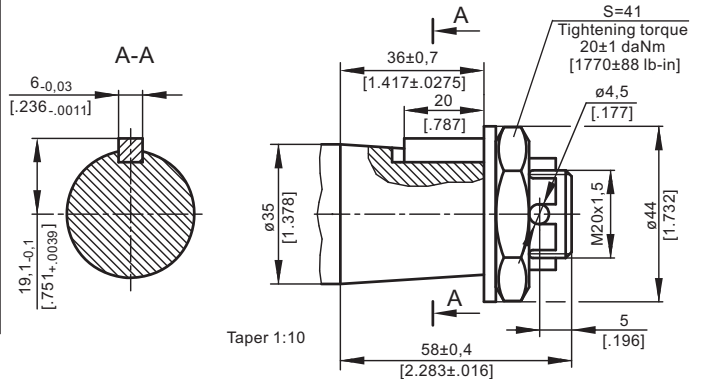

HYDRAULIC DISC BRAKE FOR FLANGE ATTACHMENT TO MSS AND MSV HYDRAULIC MOTORS

TYPE LBS/289

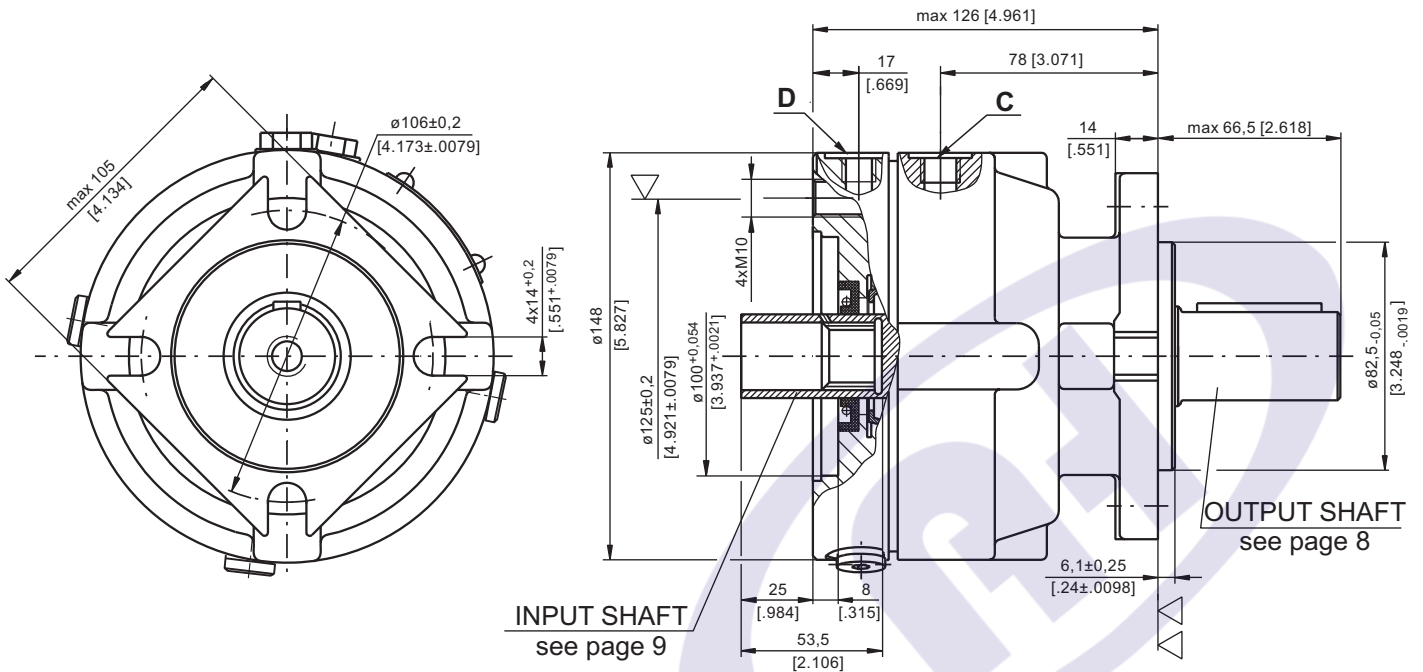

- ▽ - Place for attachment:
LBS - tightening torque for screw M10x35 - 8.8 DIN 912 - 5 daNm [440 lb-in]
LBV - tightening torque for screw M10xL - 12.9 DIN 931 - 6⁺¹ daNm [530⁺⁹⁰ lb-in]

▽▽ - Place for attachment



- C:** Brake release Port - G¹/₄, 9 mm [.35 in] depth
- D:** Drain plug for the Brake - G¹/₄, 9 mm [.35 in] depth
- T:** Drain plug for the Motor - G¹/₄, 9 mm [.35 in] depth

TYPE LBV/289

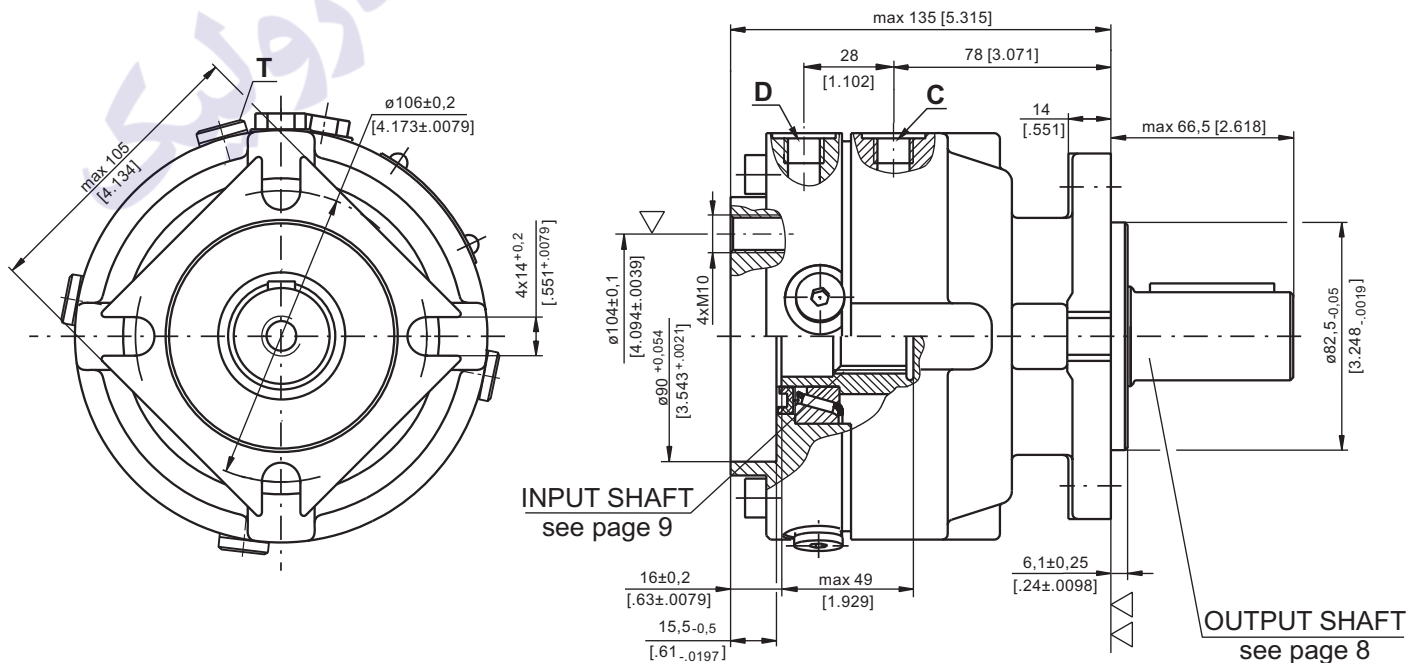

HYDRAULIC DISC BRAKE FOR FLANGE ATTACHMENT TO MSS AND MSV HYDRAULIC MOTORS

TYPE LBS/290

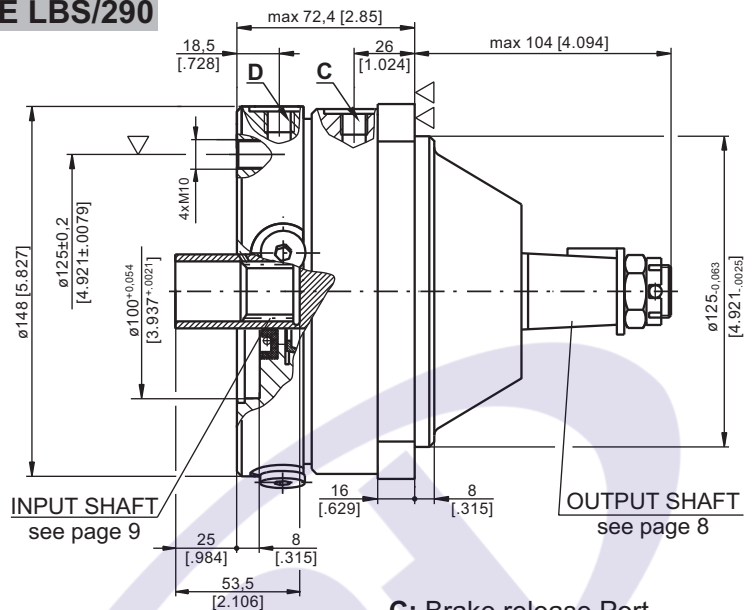
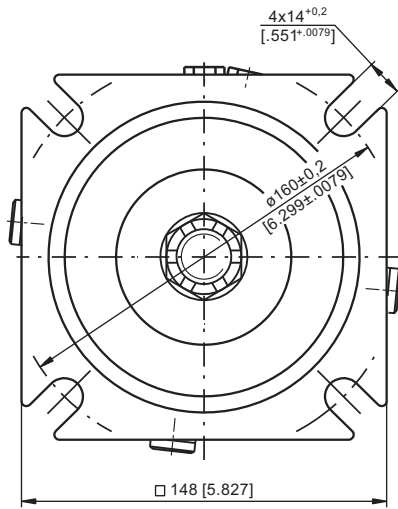

▽ - Place for attachment:

LBS - tightening torque for screw M10x35 - 8.8 DIN 912 - 5 daNm [440 lb-in]

LBV - tightening torque for screw M10xL - 12.9 DIN 931 - 6⁺ daNm [530⁹⁰ lb-in]

▽▽ - Place for attachment

C: Brake release Port

- G¹/₄, 9 mm [.35 in] depth

D: Drain plug for the Brake

- G¹/₄, 9 mm [.35 in] depth

T: Drain plug for the Motor

- G¹/₄, 9 mm [.35 in] depth

TYPE LBV/290

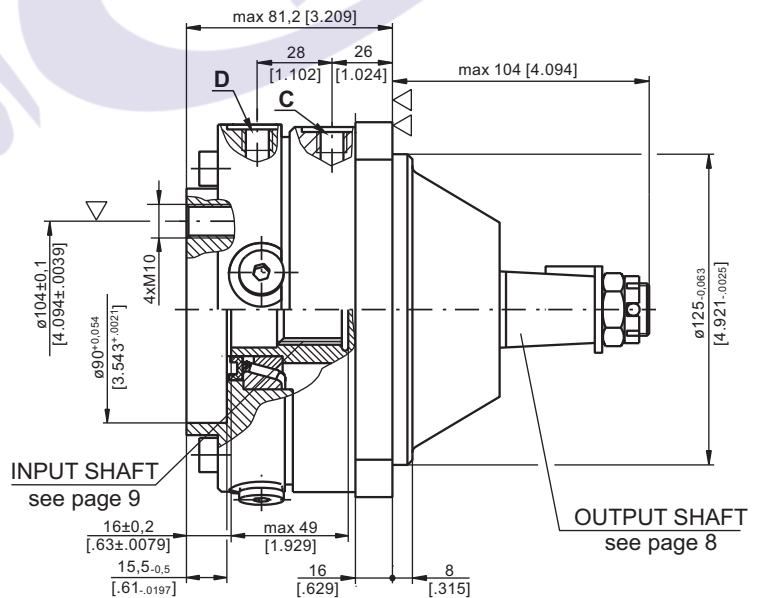
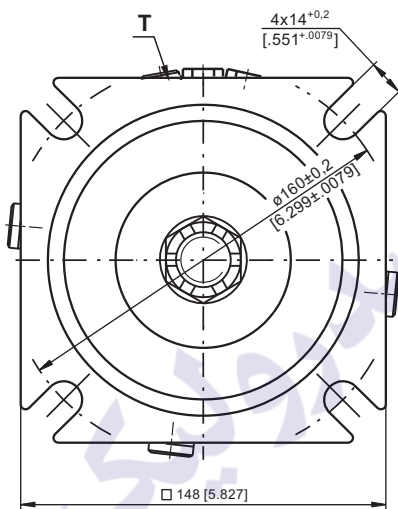

TYPE LBS/289(290)

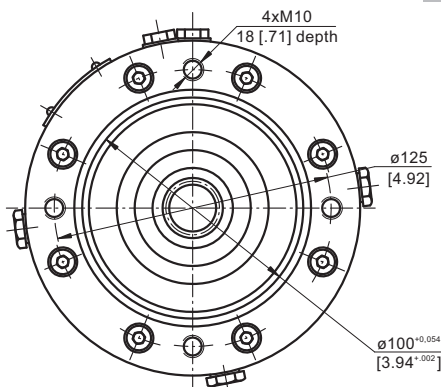

INPUT FACE For Versions 289 and 290

TYPE LBV/289(290)

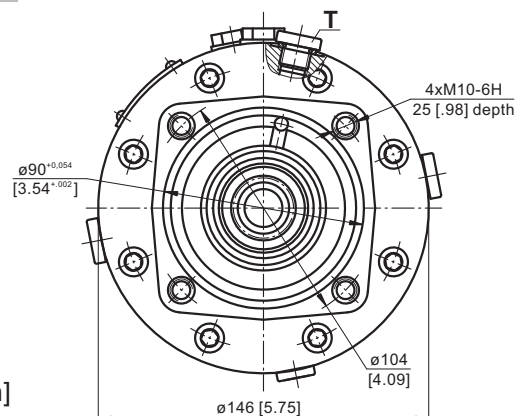

OUTPUT SHAFT EXTENSIONS

CB - $\phi 32$ straight, Parallel key A10x8x45 DIN 6885
Max. Torque 77 daNm [6815 lb-in]

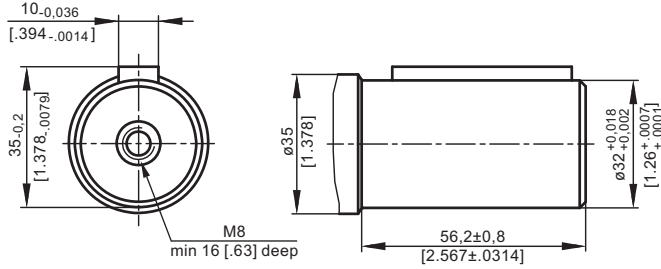

KB - tapered 1:10, Parallel key B6x6x20 DIN 6885
Max. Torque 95 daNm [8400 lb-in]

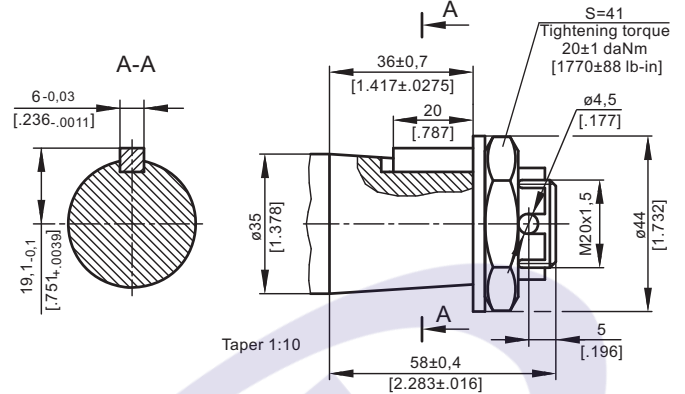

SPECIFICATION DATA

SH - $\phi 1\frac{1}{4}$ " splined 14T, DP12/24 ANS B92.1-1970
Max. Torque 95 daNm [8400 lb-in]

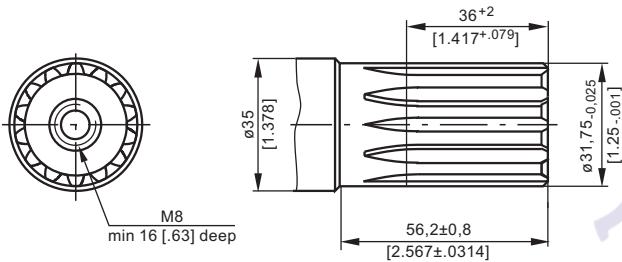

Description LBS/289(290) LBV/289(290)	21	32	43	63
*Min. Static Torque, daNm [lb-in]	20-22 [1770-1947]	31-34 [2743-3009]	41-45 [3628-3982]	61-64 [5399-5665]
Opening Pressure, bar [PSI]	min	12-13 [174-188]	18-20 [260-290]	24-26 [348-377]
	max	300 [4350]		
Min. oil quantity for brake releasing	cm ³ [in ³] 7 - 8 [427 - .488]			
Oil volume	cm ³ [in ³] 50 - 120 [3.05 - 7.35]			
Max. Pressure in drain space	bar [PSI] 5 [72]			
Weight	kg [lb] 9 [19.8]			

*Static torque is obtained at working pressure - 0 bar [0 PSI].

LOAD CURVE

The curve applies to a B10 bearing life of 3000 hours at 200 RPM.

- 1: Pa < 350 daN [787 lbs]
- 2: Pa = 500 daN [1125 lbs]

LBS(V)/289

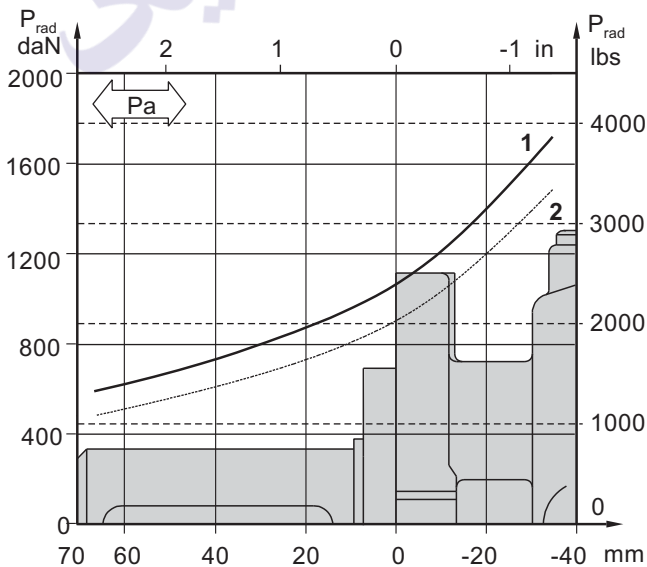

LBS(V)/290

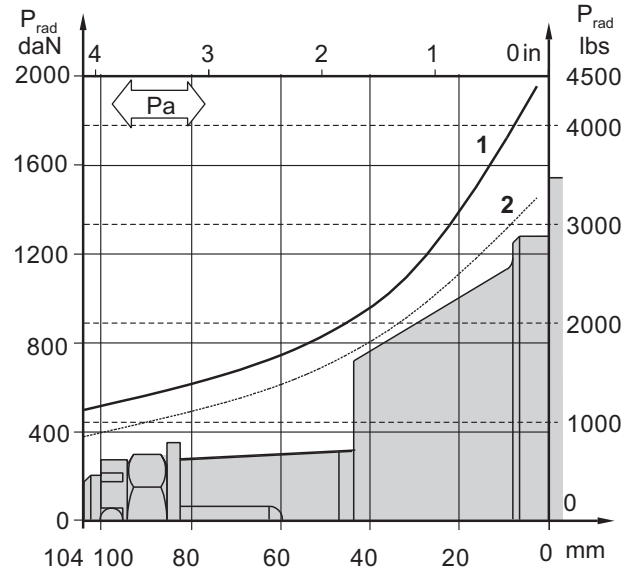

INTERNAL SPLINE DATA FOR THE ATTACHED COMPONENT

Standard ANS B92.1-1970, class 5

[m=2.1166]

Fillet Root Side Fit	LBS(V)/289 LBS(V)/290		LBS(V)/314 LBS(V)/315		
	mm	inch	mm	inch	
Number of Teeth	z	12	12	16	16
Diametral Pitch	DP	12/24	12/24	12/24	12/24
Pressure Angle		30°	30°	30°	30°
Pitch Dia.	D	25,4	1	33,8656	1.3333
Major Dia.	D _{ri}	28,0 ^{-0,1}	1.1 ± 1.098	38,4 ^{+0,4}	1.5118±1.5275
Minor Dia.	D _i	23,0 ^{+0,033}	.907 ± .905	32,15 ^{+0,06}	1.2657±1.2673
Space Width [Circular]	Lo	4,308±0,020	.1704 ± .1688	4,516±0,037	.1763±.1791
Fillet Radius	R	0,2	.008	0,5	.02
Max. Measurement between Pins	L	17,62 ^{+0,15}	.699 ± .694	26,9 ^{+0,10}	1.063±1.059
Pin Dia.	d	4,835±0,001	.19039±.19031	4,835±0,001	.19026±.19034
Corrected	x.m	+0,8	+0.031	+1,0	+0.039

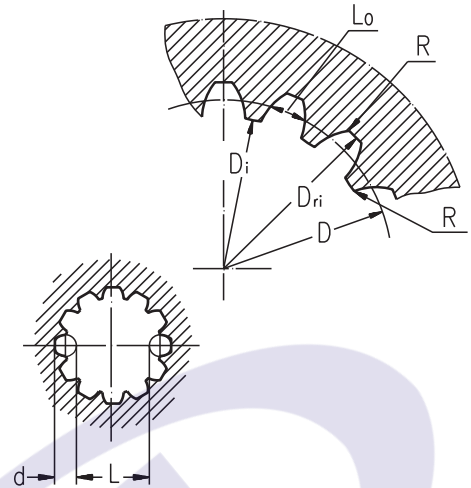

ORDER CODE - LB/288

1	2	3	4	5
LB/288	-			

Pos.1 - Input Shaft Hole

C, CO, SH, CB, SB

Pos.2 - Static Torque code (See Specification data)

7, 14, 21, 32, 43, 63

Pos.3 - Output Shaft Extensions*

C - ø25 straight, Parallel key A8x7x32 DIN 6885

CO - ø1" straight, Parallel key ¼"x¼"x1¼" BS46

SH - ø25,32 splined BS 2059 (SAE 6B)

SA - ø24,5 splined B25x22 DIN 5482

CB - ø32 straight, Parallel key A10x8x45 DIN 6885

KB - ø35 tapered 1:10, Parallel key B6x6x20 DIN6885

Pos.4 - Option (Paint)**

omit - no Paint

P - Painted

PC - Corrosion Protected Paint

Pos.5 - Design Series

omit - Factory specified

ORDER CODE - LBS, LBV

1	2	3	4	5	6
LB	/	-			

Pos.1 - Type

S - Disc Brake for short motor S- MSS

V - Disc Brake for very short motor V- MSV

Pos.2 - Design code

289 - for MSS and MSV Motors

290 - for MSS and MSV Motors (Wheel Mount)

Pos.3 - Static Torque code (See Specification data)

21, 32, 43, 63

Pos.4 - Output Shaft Extensions*

CB - ø32 straight, Parallel key A10x8x45 DIN 6885

KB - ø35 tapered 1:10, Parallel key B6x6x20 DIN6885

SH - ø1¼" splined 14T ANS B92.1-1970

Pos.5 - Option (Paint)**

omit - no Paint

P - Painted

PC - Corrosion Protected Paint

Pos.6 - Design Series

omit - Factory specified

NOTES:

* The permissible output torque for shafts must not be exceeded! For Max. Torque values see data on page 5 and 8.

** The color is by customer's request.

The Disc Brakes are mangano-phosphatized as standard.

ATTENTION:

1. Hydraulic brake is delivered without oil (it is lubricated only).

2. Hydraulic brake is filled through the drain port **D**. Space is filled with 50 ÷ 120 cm³ [3.05÷7.32 in³] mineral oil HLP (DIN 51524) or HM (ISO 6743/4). For LB/288 fill oil after hydraulic motor assembly.

3. In all brakes, friction discs and separators should be lubricated.

**HYDRAULIC DISC BRAKES
FOR FLANGE ATTACHMENT TO MTS AND MTV HYDRAULIC MOTORS**

TYPE LBS/314

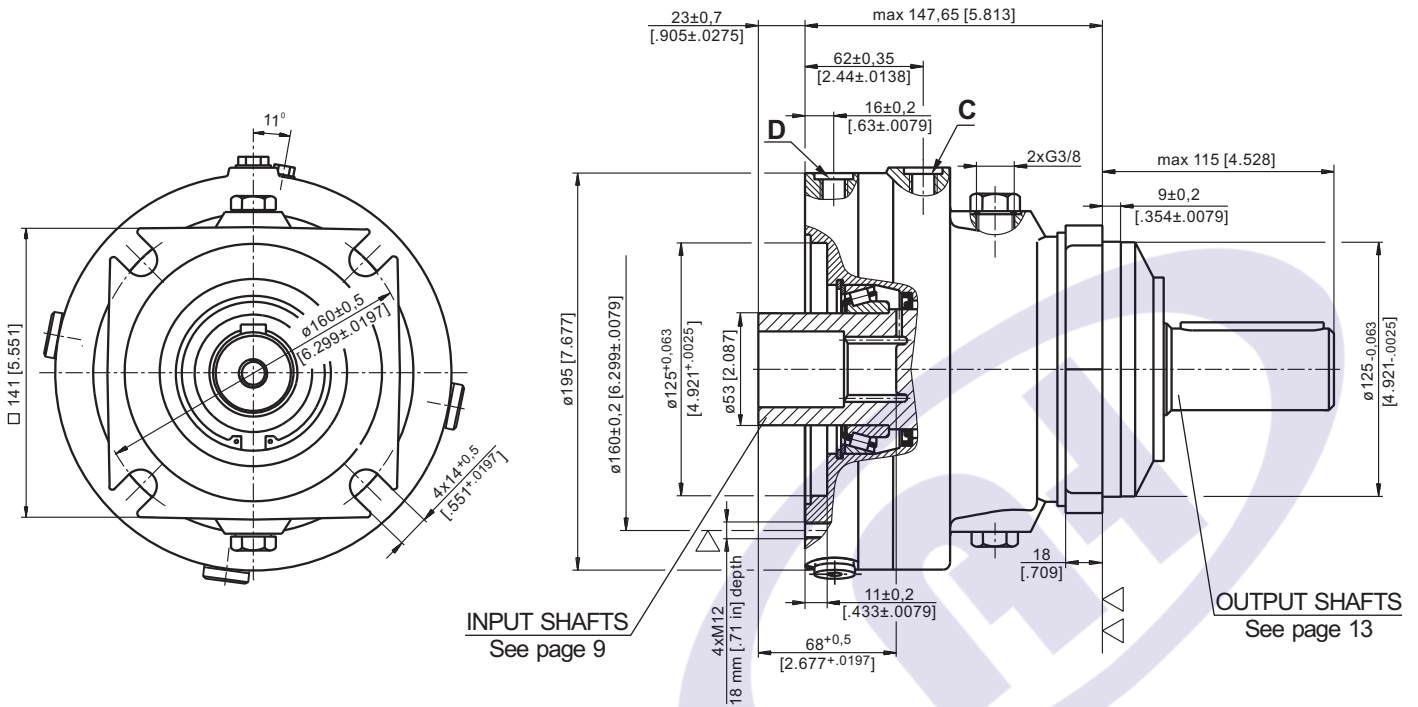

▽ - Place for attachment
(tightening torque for screw M12x30- 8.8 DIN 912,
7 daNm [620 lb-in])

▽▽ - Place for attachment

C: Brake release Port - G $\frac{1}{4}$, 12 mm [.47 in] depth
D: Drainage tap - G $\frac{1}{4}$, 12 mm [.47 in] depth

TYPE LBV/314

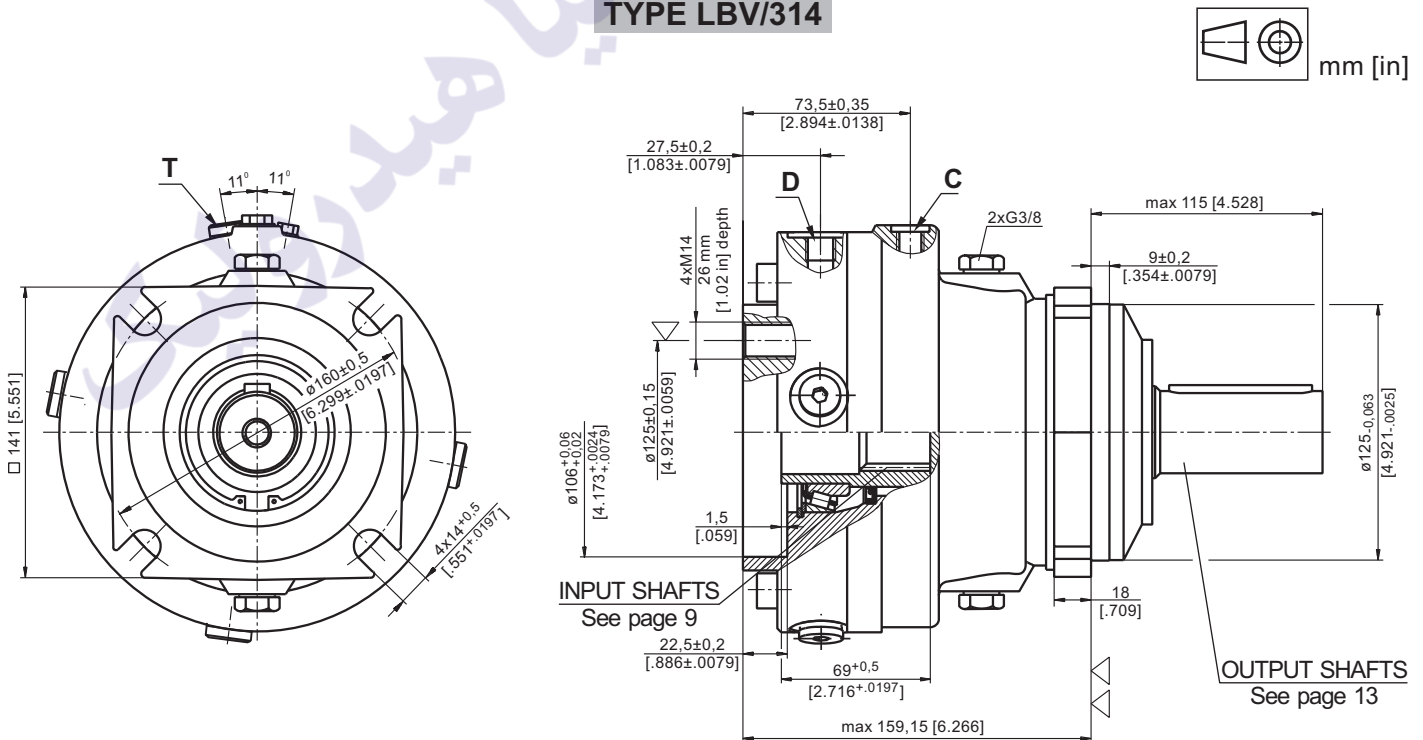

▽ - Place for attachment
(tightening torque for screw M14xL - 8.8 DIN 912,
11,5 daNm [1020 lb-in])

▽▽ - Place for attachment

C: Brake release Port - G $\frac{1}{4}$, 9 mm [.35 in] depth
D: Drain plug for the Brake - G $\frac{1}{4}$, 9 mm [.35 in] depth
T: Drain plug for the Motor - G $\frac{1}{4}$, 9 mm [.35 in] depth

HYDRAULIC DISC BRAKES
FOR FLANGE ATTACHMENT TO MTS AND MTV HYDRAULIC MOTORS

TYPE LBS/315

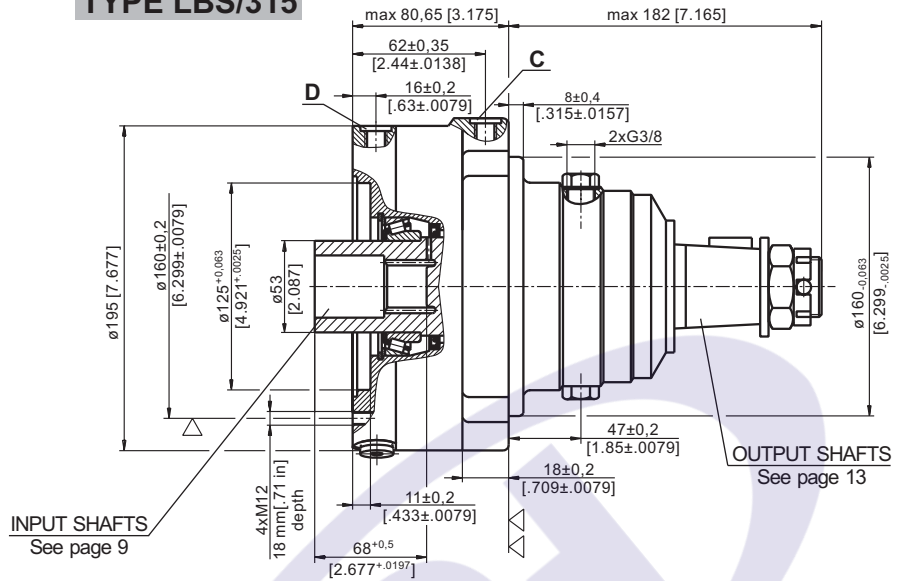
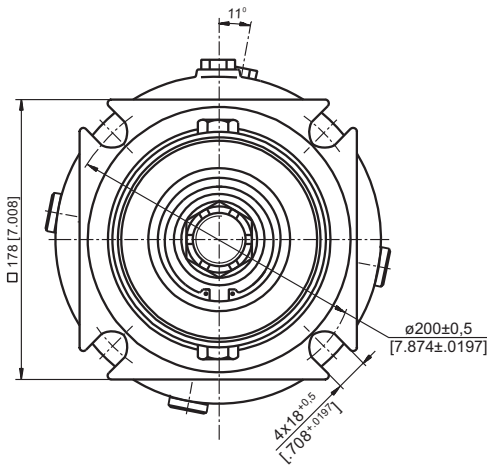

- ▽ - Place for attachment (tightening torque for screw M12x30- 8.8 DIN 912, 7 daNm [620 lb-in])
- ▽▽ - Place for attachment

- C:** Brake release Port - G $\frac{1}{4}$, 12 mm [.47 in] depth
- D:** Drainage tap - G $\frac{1}{4}$, 12 mm [.47 in] depth

TYPE LBV/315

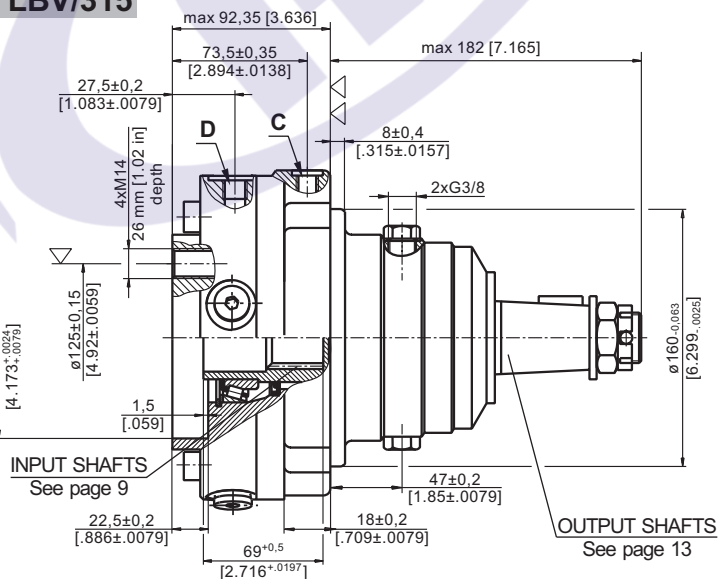
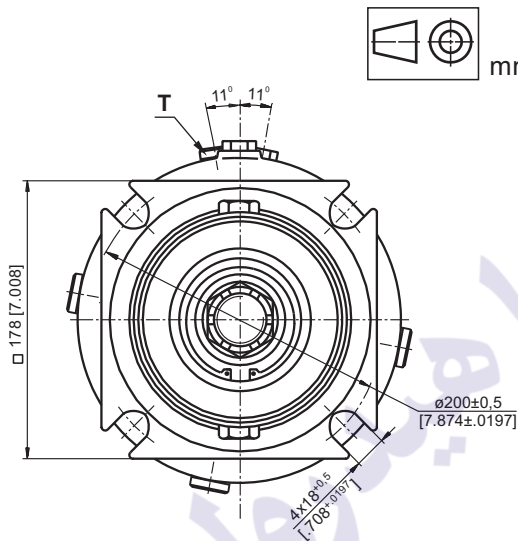

- ▽ - Place for attachment (tightening torque for screw M14xL - 8.8 DIN 912, 11,5 daNm [1020 lb-in])
- ▽▽ - Place for attachment

- C:** Brake release Port - G $\frac{1}{4}$, 9 mm [.35 in] depth
- D:** Drain plug for the Brake - G $\frac{1}{4}$, 9 mm [.35 in] depth
- T:** Drain plug for the Motor - G $\frac{1}{4}$, 9 mm [.35 in] depth

INPUT FACE
For Versions 314 and 315

TYPE LBS/314(315)

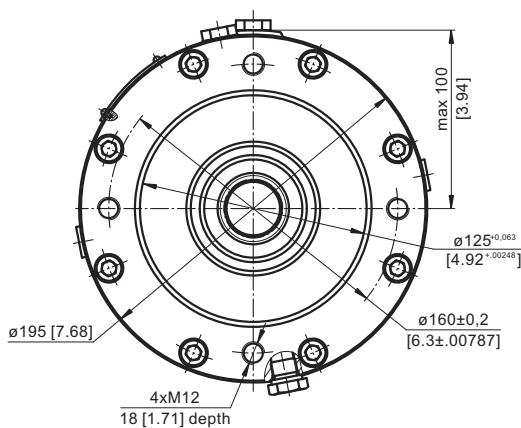

TYPE LBV/314(315)

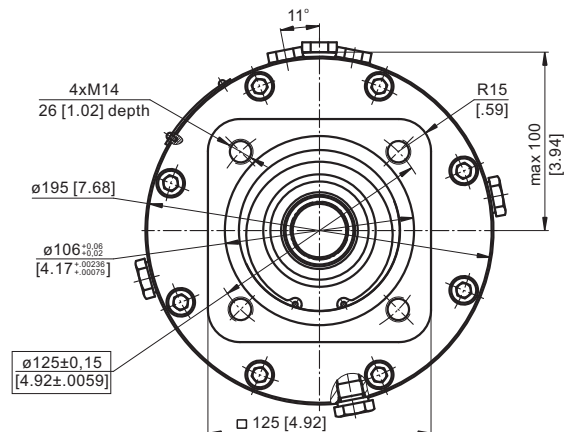

SPECIFICATION DATA

Description	LBS/314,315	21	29	43	65	85	110	130
*Min. Static Torque, daNm [lb-in]		18-23 [1593-2036]	28-33 [2478-2921]	42-46 [3717-4071]	61-70 [5399-6196]	83-92 [7346-8143]	108-118 [9559-10444]	126-136 [11152-12037]
Opening Pressure min** bar [PSI]		4-5 [58-72]	6-7 [87-101]	9-10 [130-145]	13-15 [188-217]	18-20 [261-290]	23-25 [333-362]	27-29 [391-420]
	max	300 [4350]						
Min. oil quantity for brake releasing cm ³ [in ³]		8-9 [.488-.549]						
Oil volume cm ³ [in ³]		250						
Max. Pressure in drain space bar [PSI]		5 [72]						
Weight for .../314 kg [lb]		24 [52.9]						
	.../315	25 [55.1]						

*Static torque is obtained at working pressure - 0 bar.

**The indicated value is a difference between the inlet pressure for driving of the brake and the drain pressure.
Brakes must always have a drain line

LOAD CURVE

LBS(V) ... /314

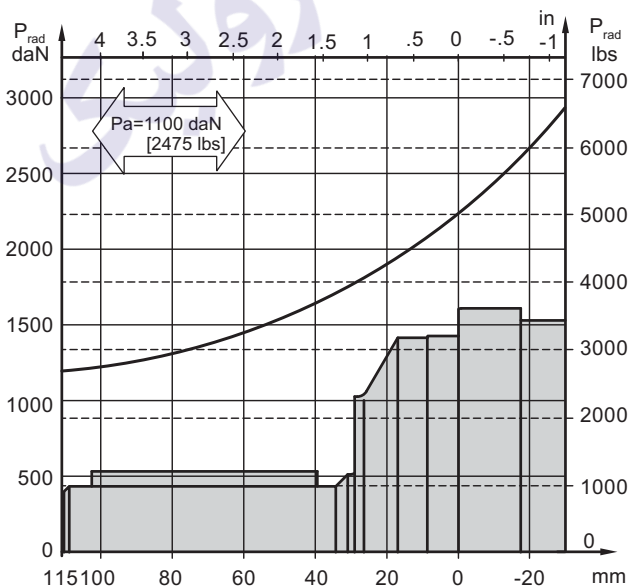

LBS(V) ... /315

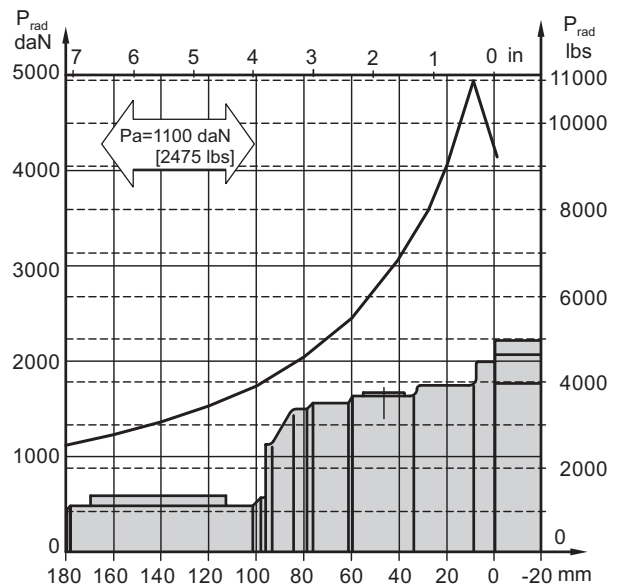

OUTPUT SHAFT EXTENSIONS

C - ϕ 40 straight, Parallel key A12x8x70 DIN 6885
Max. Torque 132,8 daNm [11755 In-in]

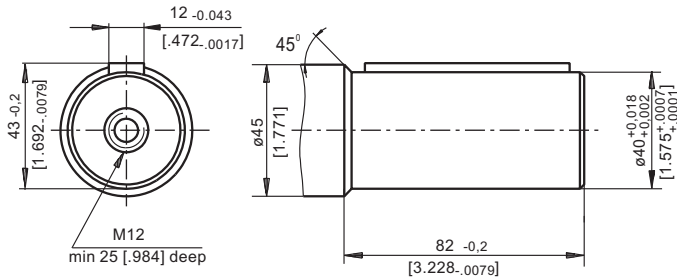

K -tapered 1:10, Parallel key B12x8x28 DIN 6885
Max. Torque 210,7 daNm [18650 lb-in]

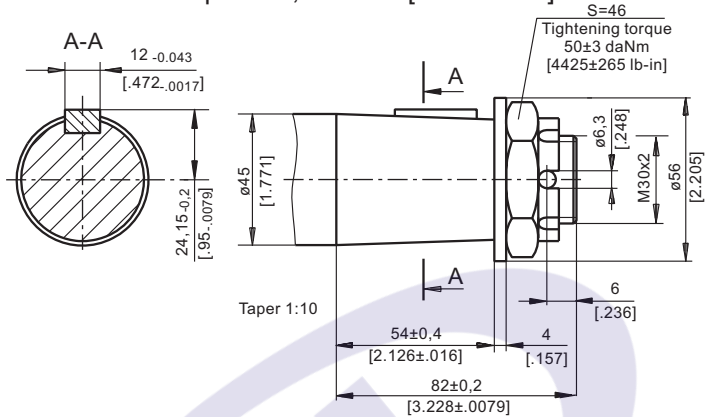

CO - ϕ 1 1/2" straight, Parallel key 3/8" x 3/8" x 2 1/4" BS46
Max. Torque 132,8 daNm [11755 In-in]

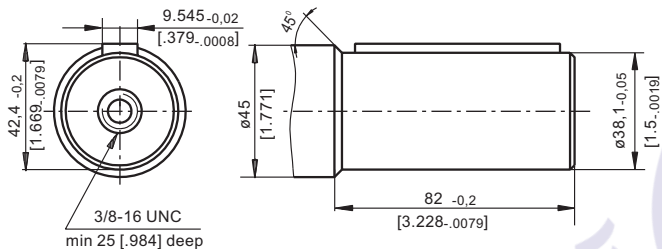

SH - ϕ 1 1/2" splined 17T, DP 12/24 ANSI B92.1-1976
Max. Torque 132,8 daNm [11755 In-in]

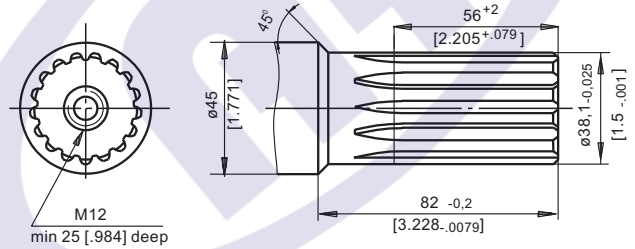

ORDER CODE

1	2	3	4	5	6
LB	/	-			

Pos.1 - Type

- S** - Disc Brake for short motor **S** - MTS
- V** - Disc Brake for very short motor **V** - MTV

Pos.2 - Design code

- 314** - for MTS and MTV Motors
- 315** - for MTS and MTV Motors (Wheel Mount)

Pos.3 - Static Torque code (See Specification data)

21, 29, 43, 65, 85, 110, 130

Pos.4 - Output Shaft Extensions*

- C** - ϕ 40 straight, Parallel key A12x8x70 DIN 6885
- CO** - ϕ 1 1/2" straight, Parallel key 3/8" x 3/8" x 2 1/4" BS46
- SH** - ϕ 1 1/2" splined 17T, ANSI B92.1-1976
- K** - ϕ 45 tapered 1:10, Parallel key B12x8x28 DIN6885

Pos.5 - Option (Paint)**

- omit - no Paint
- P** - Painted
- PC** - Corrosion Protected Paint

Pos.6 - Design Series

- omit - Factory specified

NOTES:

- * The permissible output torque for shafts must not be exceeded!
- ** The color is by customer's request.

The Disc Brakes are mangano-phosphatized as standard.

ATTENTION:

- Hydraulic brake is delivered without oil (it is lubricated only).
- Fill the brake through the drain port **D** with 50 ÷ 120 cm³ [3.05÷7.32 in³] mineral oil HLP (DIN 51524) or HM (ISO 6743/4). LB/288 must be filled after the motor is assembled on the brake.
- In all brakes, friction discs and separators should be lubricated.

**HYDRAULIC DISC BRAKES
FOR FLANGE ATTACHMENT TO MVS HYDRAULIC MOTORS**

Type LBS/313

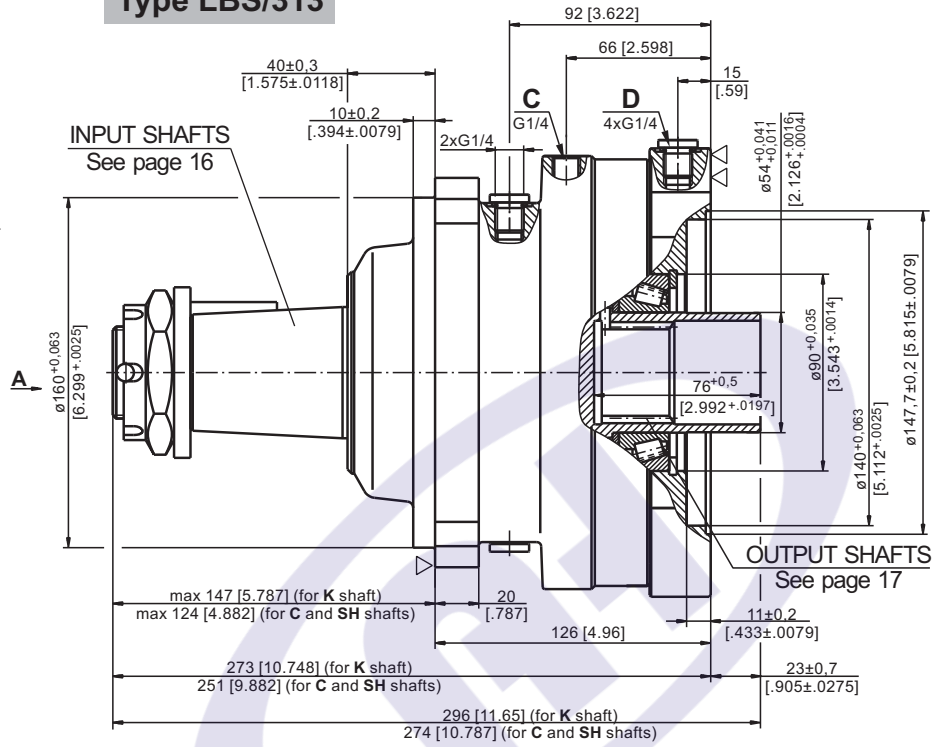
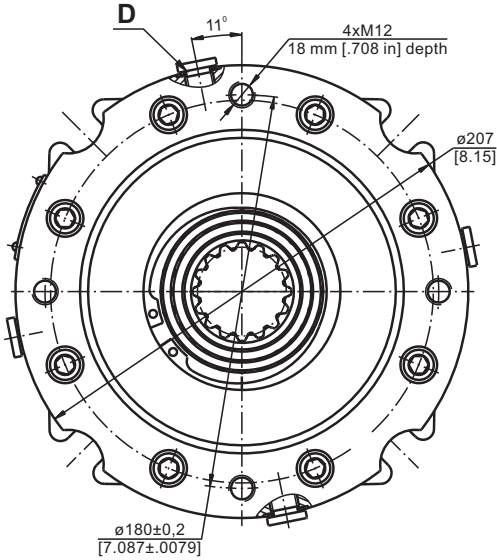

C: Brake release Port - G $\frac{1}{4}$, 12 mm [.47 in] depth
D: Drainage tap - G $\frac{1}{4}$, 12 mm [.47 in] depth

▽ - Place for attachment
▽▽ - Place for attachment
(tightening torque for screw M12x35 - 8.8 DIN 912, 7 daNm [620 lb-in])

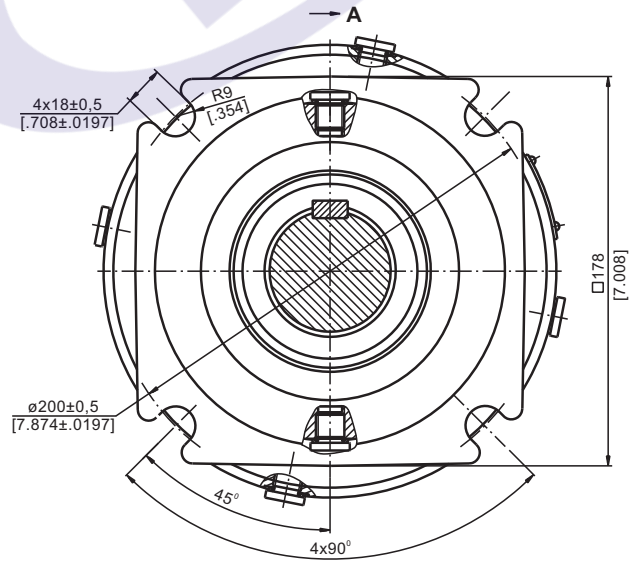

PERMISSIBLE SHAFT LOADS

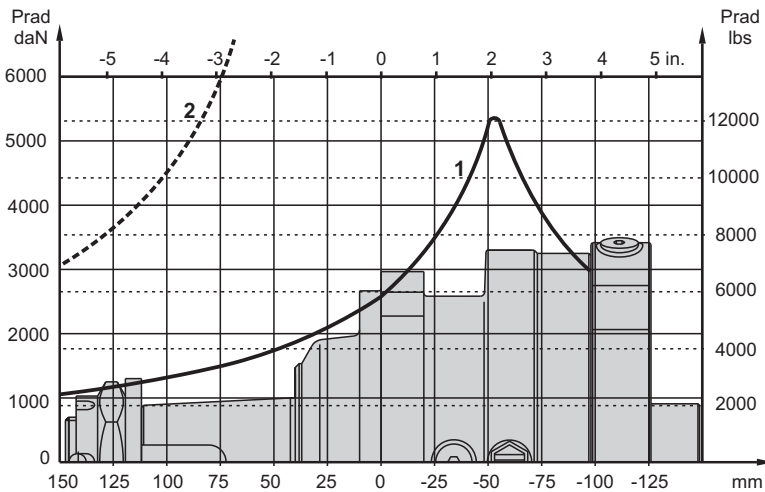

1 - Bearing curve: The curve applies to a B10 bearing life of 3000 hours at 200 RPM.
2 - Shaft curve: The curve represents Max. permissible radial shaft load with safety factor 3:1.

**HYDRAULIC DISC BRAKES
FOR FLANGE ATTACHMENT TO MVS HYDRAULIC MOTORS**

Type LBS/316

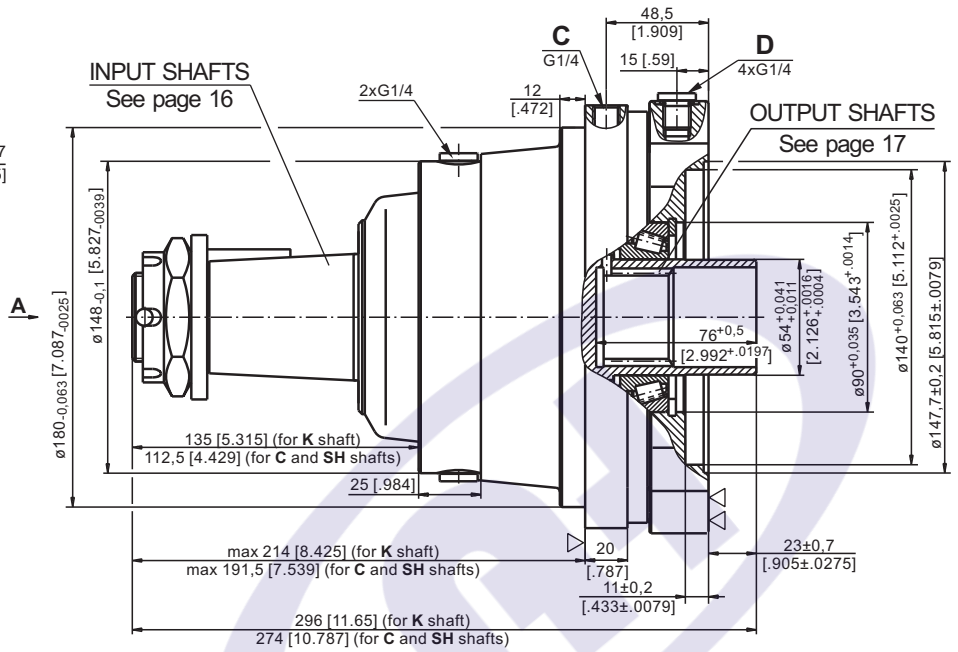
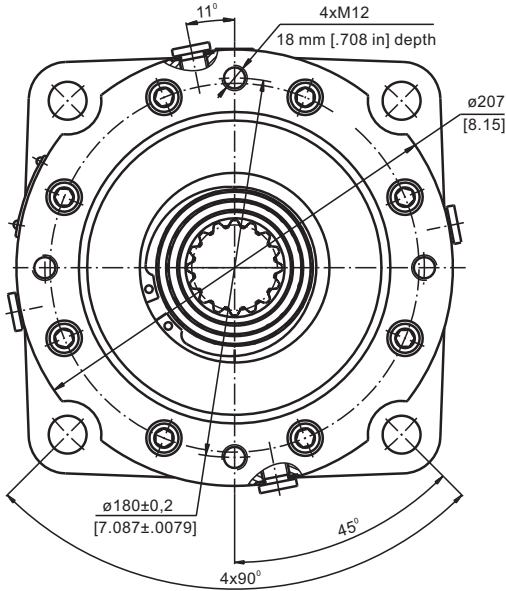

C: Brake release Port - G $\frac{1}{4}$, 12 mm [0.47 in] depth

D: Drainage tap - G $\frac{1}{4}$, 12 mm [0.47 in] depth

▽ - Place for attachment

▽▽ - Place for attachment
(tightening torque for screw M12x35 - 8.8 DIN 912,
7 daNm [620 lb-in])

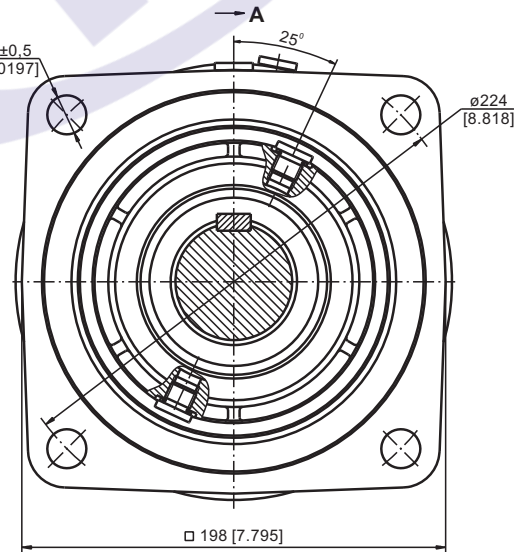

PERMISSIBLE SHAFT LOADS

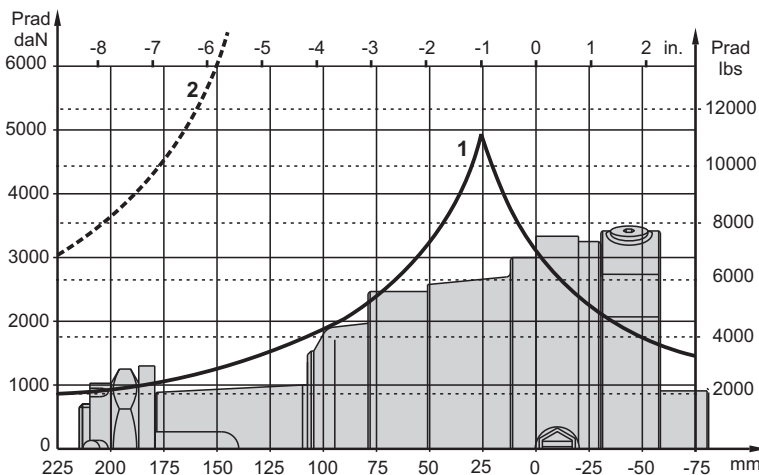

- 1 - Bearing curve: The curve applies to a B10 bearing life of 3000 hours at 200 RPM.
- 2 - Shaft curve: The curve represents Max. permissible radial shaft load with safety factor 3:1.

SPECIFICATION DATA

Description LBS/313,316	21	29	43	65	85	110	130
*Min. Static Torque, daNm [lb-in]	18-23 [1593-2036]	28-33 [2478-2921]	42-47 [3717-4160]	61-71 [5399-6285]	83-94 [7346-8320]	108-118 [9559-10444]	127-137 [11240-12125]
Opening Pressure min** bar [PSI]	4-5 [58-72]	6-7 [87-101]	9-10 [130-145]	13-15 [188-217]	18-20 [261-290]	23-25 [333-362]	27-29 [391-420]
	max 300 [4350]						
Min. oil quantity for brake releasing cm ³ [in ³]	8 ÷ 9 [.488 ÷ .549]						
Oil volume cm ³ [in ³]	250 [15.25]						
Max. Pressure in drain space bar [PSI]	5 [72]						
Weight for .../313 kg [lb]	25 [55.1]						
	.../316 26 [57.3]						

*Static torque is obtained at working pressure - 0 bar.

**The indicated value is a difference between the inlet pressure for driving of the brake and the drain pressure.

Brakes must always have a drain line

SHAFT EXTENSIONS

C - ø50 straight, Parallel key A14x9x70 DIN 6885

SH -ø21/8"splined, 16 DP 8/16 ANS B92.1-1976

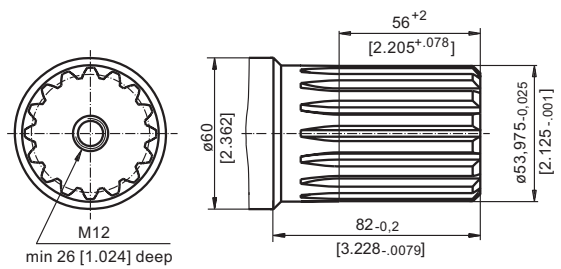
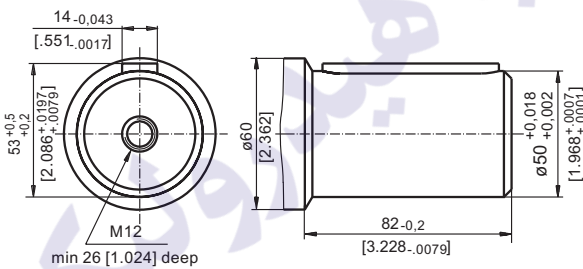

K -tapered 1:10, Parallel key B16x10x32 DIN 6885

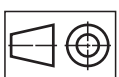
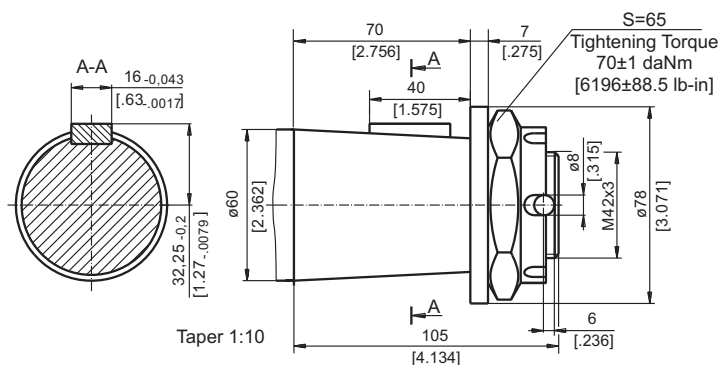

mm [in]

INTERNAL SPLINE DATA FOR THE ATTACHED COMPONENT

Standard ANS B92.1-1970, class 5
[m=2.54; corrected x.m=+1,0]

Fillet Root Side Fit		mm	inch
Number of Teeth	z	16	16
Diametral Pitch	DP	10/20	10/20
Pressure Angle		30°	30°
Pitch Dia.	D	40,640	1.6
Major Dia.	D _{ri}	45,2 ^{+0,4}	1.796÷1.780
Minor Dia.	D _i	38,5 ^{+0,039}	1.5175÷1.516
Space Width [Circular]	L _o	5,18±0,037	.2055÷.2025
Fillet Radius	R	0,4	.015
Max. Measurement between Pins	L	32,47 ^{+0,15}	1.284÷1.278
Pin Dia.	d	5,6±0,001	.22051÷.22043

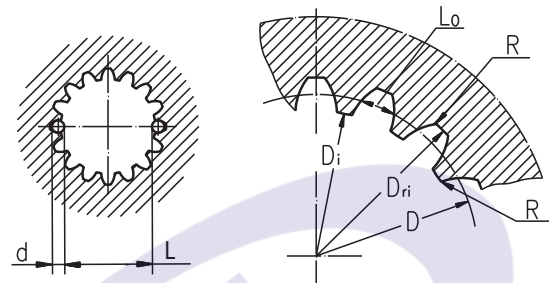

Hardening Specification:
HV=750±50 on the surface.
HV=560 at 0,7±0,2 mm [.035±.019in] case depth
Material: 20 MoCr4 EN 10084 or better.

ORDER CODE

	1	2	3	4	5
LBS/		-			

Pos.1 - Designe code

- 313** - for MVS Motors
- 316** - for MVS Motors (Wheel mount)

Pos.2 - Static Torque code (See Specification data)

21, 29, 43, 65, 85, 110, 130

Pos.3 - Output Shaft Extensions*

- C** - ø50 straight, Parallel key A14x9x70 DIN6885
- SH** - ø2 1/8" splined, ANSI B92.1-1976
- K** - ø60 tapered 1:10, Parallel key B16x10x32 DIN6885

Pos.4 - Option (Paint)**

- omit - no Paint
- P** - Painted
- PC** - Corrosion Protected Paint

Pos.5 - Design Series

omit - Factory specified

NOTES:

- * The permissible output torque for shafts must be not exceeded!
- ** The color is by customer's request.

The Disc Brakes are mangano-phosphatized as standard.

ATTENTION:

1. Hydraulic brake is delivered without oil (it is lubricated only).
2. In all brakes, friction discs and separators should be lubricated. Space is filled with 150 ÷ 300 cm³ [9.15 ÷ 18.3 in³] mineral oil HLP (DIN 51524) or HM (ISO 6743/4).