

HYDRAULIC MOTORS MT

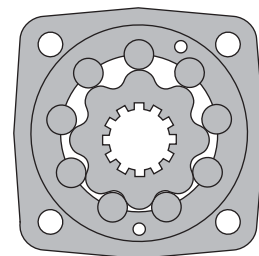

APPLICATION

- » Conveyors
- » Metal working machines
- » Agricultural machines
- » Road building machines
- » Mining machinery
- » Food industries
- » Special vehicles
- » Plastic and rubber machinery etc.

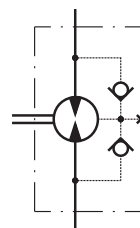

CONTENTS

Specification data	26÷27
Function diagrams	28+31
Dimensions and mounting	32+33
Shaft extensions	34
Permissible Shaft Seal pressure	34
Dimensions and mounting- MTS, V	35+36
Internal Spline data	37
Permissible shaft loads	37
Tacho connection	38
Order code	38

OPTIONS

- » Model - Disc valve, roll-gerotor
- » Flange with wheel mount
- » Short motor
- » Tacho connection
- » Speed sensing
- » Side and rear ports
- » Shafts - straight, splined and tapered
- » Metric and BSPP ports
- » Other special features

GENERAL

Max. Displacement, cm ³ /rev [in ³ /rev]	724,3 [44.2]
Max. Speed, [RPM]	775
Max. Torque, daNm [lb-in]	cont.: 130 [11500] int.: 148 [13100]
Max. Output, kW [HP]	40 [54]
Max. Pressure Drop, bar [PSI]	cont.: 200 [2900] int. 240 [3480]
Max. Oil Flow, lpm [GPM]	150 [39.6]
Min. Speed, [RPM]	5
Permissible Shaft Loads daN [lbs]	P _a =1000 [2250]
Pressure fluid	Mineral based- HLP(DIN 51524) or HM(ISO 6743/4)
Temperature range, °C [°F]	-40÷140 [-40÷284]
Optimal Viscosity range, mm ² /s [SUS]	20 ÷ 75 [98 ÷ 347]
Filtration	ISO code 20/16 (Min. recommended fluid filtration of 25 microns)

Oil flow in drain line

Pressure drop bar [PSI]	Viscosity mm ² /s [SUS]	Oil flow in drain line lpm [GPM]
140 [2030]	20 [98]	2,5 [.660]
	35 [164]	1,5 [.396]
210 [3045]	20 [98]	5 [1.321]
	35 [164]	3 [.793]

Pressure Losses

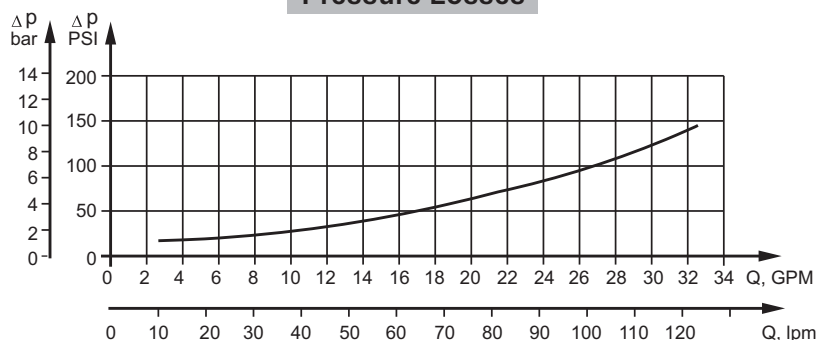

SPECIFICATION DATA

Type		MT 160	MT 200	MT 250	MT 315
Displacement, cm³/rev [in³/rev]		161,1 [9.83]	201,4 [12.29]	251,8 [15.36]	326,3 [19.90]
Max. Speed, [RPM]	Cont.	622	620	496	382
	Int.*	775	752	601	461
Max. Torque daNm [lb-in]	Cont.	47 [4160]	59 [5220]	73 [6460]	95 [8410]
	Int.*	56 [4960]	71 [6285]	88 [7790]	114 [10090]
	Peak**	66 [5840]	82 [7260]	102 [9030]	133 [11770]
Max. Output kW [HP]	Cont.	26,5 [36]	33,5 [45]	33,5 [45]	33,5 [45]
	Int.*	32 [43]	40 [54]	40 [54]	40 [54]
Max. Pressure Drop bar [PSI]	Cont.	200 [2900]	200 [2900]	200 [2900]	200 [2900]
	Int.*	240 [3480]	240 [3480]	240 [3480]	240 [3480]
	Peak**	280 [4050]	280 [4050]	280 [4050]	280 [4050]
Max. Oil Flow lpm [GPM]	Cont.	100 [26]	125 [33]	125 [33]	125 [33]
	Int.*	125 [33]	150 [39.6]	150 [39.6]	150 [39.6]
Max. Inlet Pressure bar [PSI]	Cont.	210 [3050]	210 [3050]	210 [3050]	210 [3050]
	Int.*	250 [3600]	250 [3600]	250 [3600]	250 [3600]
	Peak**	300 [4350]	300 [4350]	300 [4350]	300 [4350]
Max. Return Pressure with Drain Line bar [PSI]	Cont.	140 [2030]	140 [2030]	140 [2030]	140 [2000]
	Int.*	175 [2540]	175 [2540]	175 [2540]	175 [2500]
	Peak**	210 [3050]	210 [3050]	210 [3050]	210 [3000]
Max. Starting Pressure with Unloaded Shaft, bar [PSI]		10 [150]	10 [150]	10 [150]	10 [150]
Min. Starting Torque daNm [lb-in]	At max. press. drop Cont.	34 [3010]	43 [3800]	53 [4690]	74 [6550]
	At max. press. drop Int.*	41 [3630]	52 [4600]	63 [5580]	89 [7880]
Min. Speed***, [RPM]		10	9	8	7
Weight, kg [lb] For Rear Ports +0,450[.992]	MT	20 [44.1]	21,5 [47.4]	21 [46.3]	22 [48.5]
	MTW	22 [48.5]	22,5 [49.6]	23 [50.7]	24 [52.9]
	MTS	15 [33.1]	15,5 [34.2]	16 [35.3]	17 [37.5]
	MTV	11 [24.3]	11,5 [25.4]	12 [26.5]	13 [28.7]

* Intermittent operation: the permissible values may occur for max. 10% of every minute.

** Peak load: the permissible values may occur for max. 1% of every minute.

*** For speeds lower than given, consult factory or your regional manager.

1. Intermittent speed and intermittent pressure must not occur simultaneously.
2. Recommended filtration is per ISO cleanliness code 20/16. A nominal filtration of 25 micron or better.
3. Recommend using a premium quality, anti-wear type mineral based hydraulic oil HLP(DIN51524) or HM (ISO 6743/4).
If using synthetic fluids consult the factory for alternative seal materials.
4. Recommended minimum oil viscosity 13 mm²/s [70 SUS] at 50°C [122°F].
5. Recommended maximum system operating temperature is 82°C [180°F].
6. To assure optimum motor life fill with fluid prior to loading and run at moderate load and speed for 10-15 minutes.

SPECIFICATION DATA (continued)

Type		MT 400	MT 500	MT 630	MT 725
Displacement, cm³/rev [in³/rev]		410,9 [25.06]	523,6 [31.95]	631,2 [38.52]	724,3 [44.2]
Max. Speed, [RPM]	Cont.	304	238	197	172
	Int.*	368	289	234	209
Max. Torque daNm [lb-in]	Cont.	108 [9560]	122 [10800]	130 [11500]	127 [11240]
	Int.*	126 [11150]	137 [12125]	148 [13100]	147 [13010]
	Peak**	144 [12745]	160 [14160]	176 [15580]	175 [15490]
Max. Output kW [HP]	Cont.	30 [40]	26,5 [36]	24,3 [33]	20,2 [27]
	Int.*	35 [47]	30 [40]	27,5 [37]	26,8 [36]
Max. Pressure Drop bar [PSI]	Cont.	180 [2610]	160 [2320]	140 [2010]	120 [1740]
	Int.*	210 [3050]	180 [2610]	160 [2320]	140 [2010]
	Peak**	240 [3480]	210 [3050]	190 [2760]	165 [2395]
Max. Oil Flow lpm [GPM]	Cont.	125 [33]	125 [33]	125 [33]	125 [33]
	Int.*	150 [39.6]	150 [39.6]	150 [39.6]	150 [39.6]
Max. Inlet Pressure bar [PSI]	Cont.	210 [3050]	210 [3050]	210 [3600]	210 [3050]
	Int.*	250 [3600]	250 [3600]	250 [4350]	250 [3600]
	Peak**	300 [4350]	300 [4350]	300 [2000]	300 [4350]
Max. Return Pressure with Drain Line bar [PSI]	Cont.	140 [2000]	140 [2000]	140 [2500]	140 [2000]
	Int.*	175 [2500]	175 [2500]	175 [2500]	175 [2500]
	Peak**	210 [3000]	210 [3000]	210 [3000]	210 [3000]
Max. Starting Pressure with Unloaded Shaft, bar [PSI]		10 [150]	10 [150]	10 [150]	10 [150]
Min. Starting Torque daNm [lb-in]	At max. press. drop Cont.	84 [7435]	95 [8410]	95 [8410]	95 [8410]
	At max. press. drop Int.*	97 [8585]	106 [9380]	110 [9740]	115 [10180]
Min. Speed***, [RPM]		6	5	5	5
Weight, kg [lb] For Rear Ports +0,450[.992]	MT	23 [50.7]	24 [52.9]	23,5 [51.8]	24,5 [54.0]
	MTW	25 [55.1]	26 [57.3]	25,5 [56.2]	26,5 [58.4]
	MTS	18 [39.7]	19 [41.9]	18,5 [40.8]	19,5 [43.0]
	MTV	14 [30.9]	15 [33.1]	14,5 [32.0]	15,5 [34.2]

* Intermittent operation: the permissible values may occur for max. 10% of every minute.

** Peak load: the permissible values may occur for max. 1% of every minute.

*** For speeds lower than given, consult factory or your regional manager.

1. Intermittent speed and intermittent pressure must not occur simultaneously.
2. Recommended filtration is per ISO cleanliness code 20/16. A nominal filtration of 25 micron or better.
3. Recommend using a premium quality, anti-wear type mineral based hydraulic oil HLP(DIN51524) or HM (ISO 6743/4).
If using synthetic fluids consult the factory for alternative seal materials.
4. Recommended minimum oil viscosity 13 mm²/s [70 SUS] at 50°C [122°F].
5. Recommended maximum system operating temperature is 82°C [180°F].
6. To assure optimum motor life fill with fluid prior to loading and run at moderate load and speed for 10-15 minutes.

FUNCTION DIAGRAMS

MT 160

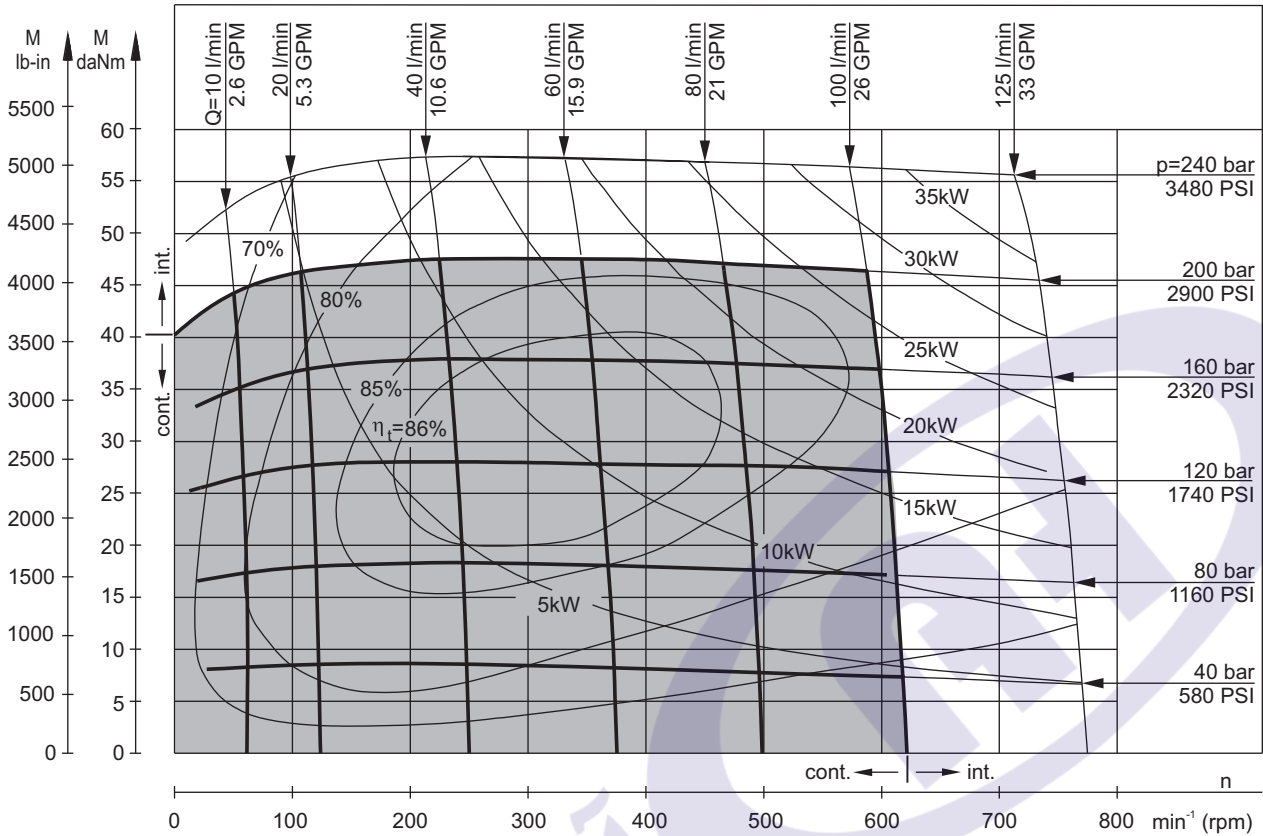

MT 200

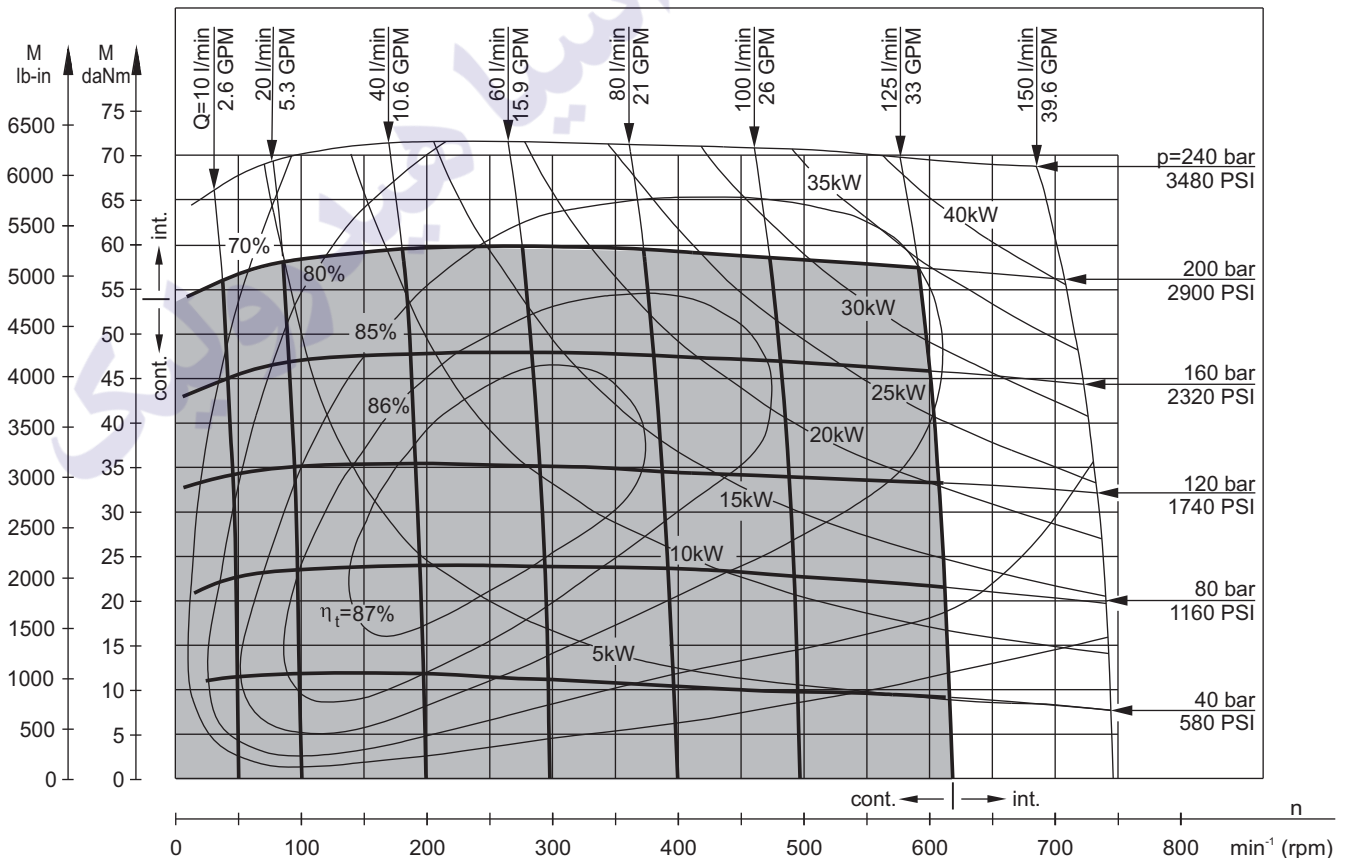

The function diagrams data is for average performance of randomly selected motors at back pressure $5 \div 10$ bar [72.5 ÷ 145 PSI] and oil with viscosity of 32 mm²/s [150 SUS] at 50°C [122°F].

FUNCTION DIAGRAMS

MT 250

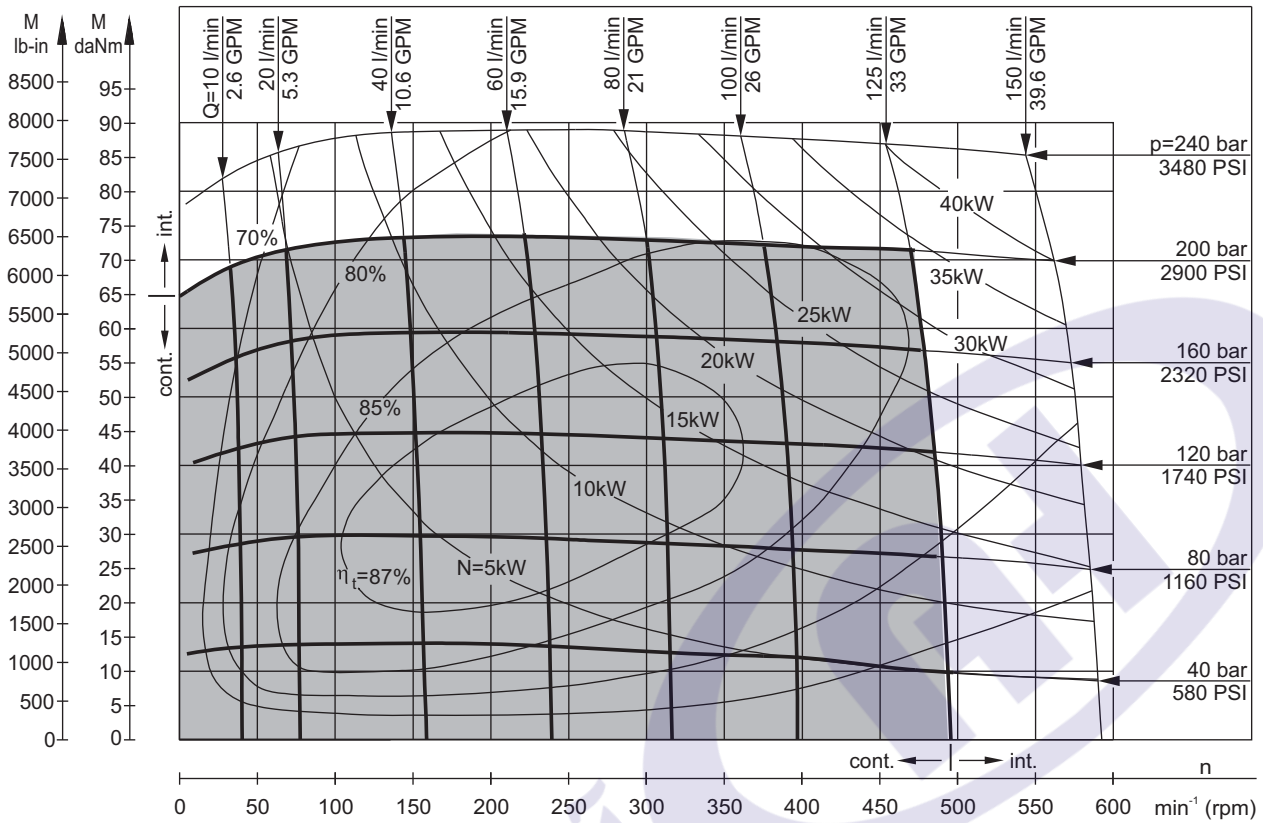

MT 315

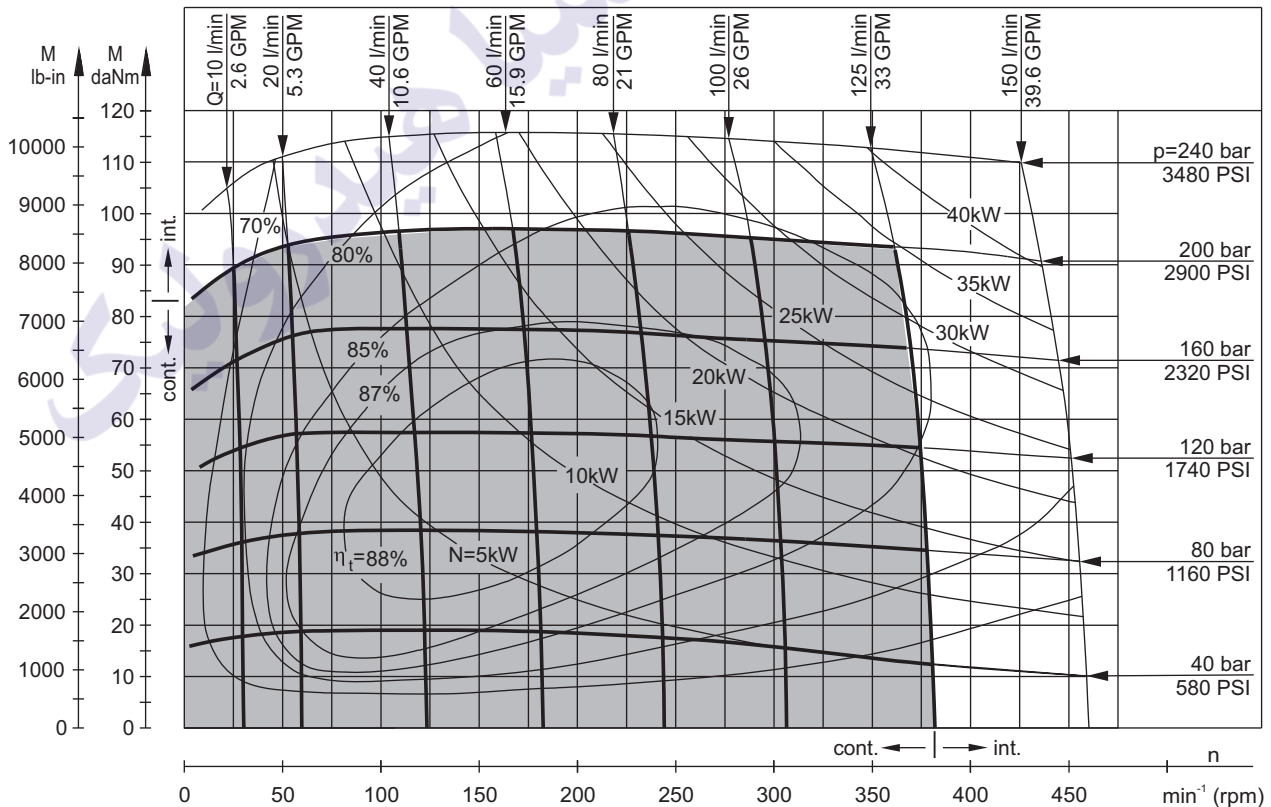

The function diagrams data is for average performance of randomly selected motors at back pressure 5÷10 bar [72.5÷145 PSI] and oil with viscosity of 32 mm²/s [150 SUS] at 50°C [122°F].



FUNCTION DIAGRAMS

MT 400

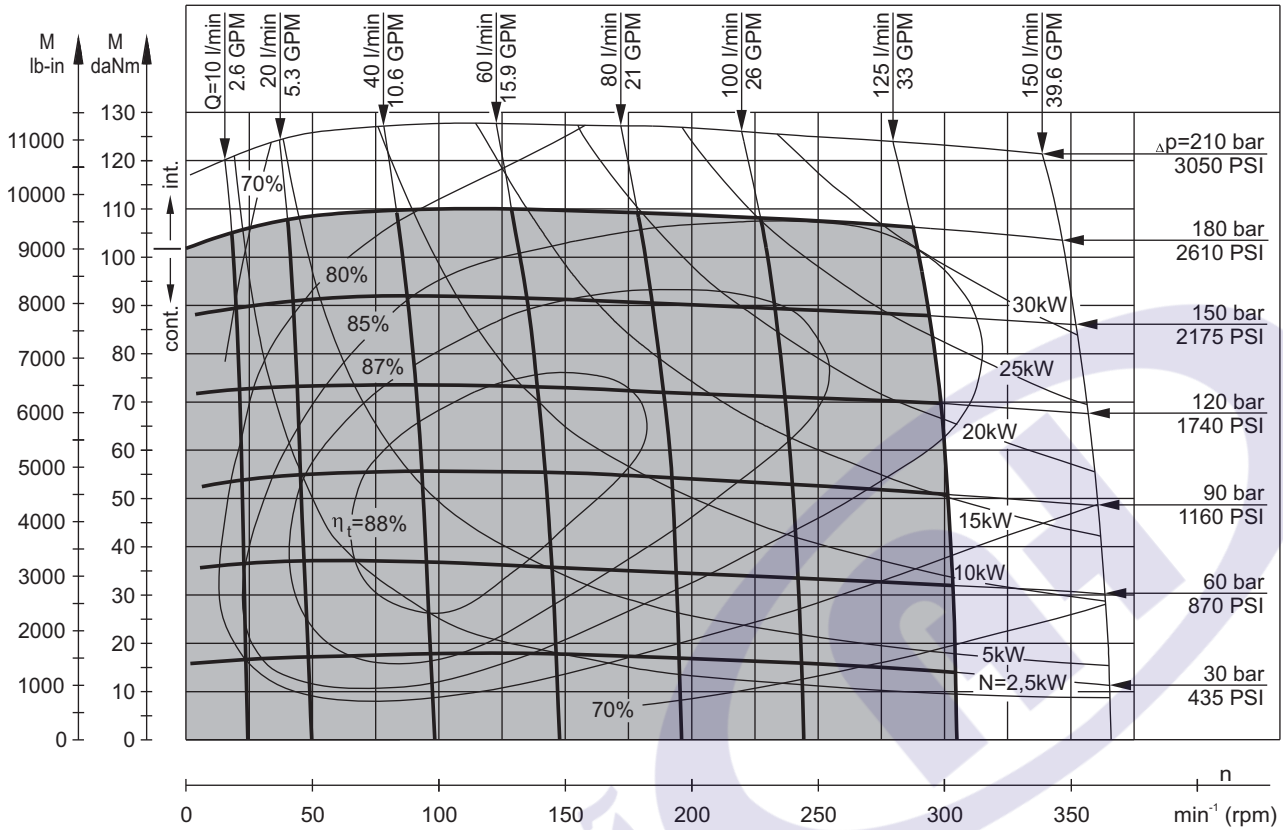

MT 500

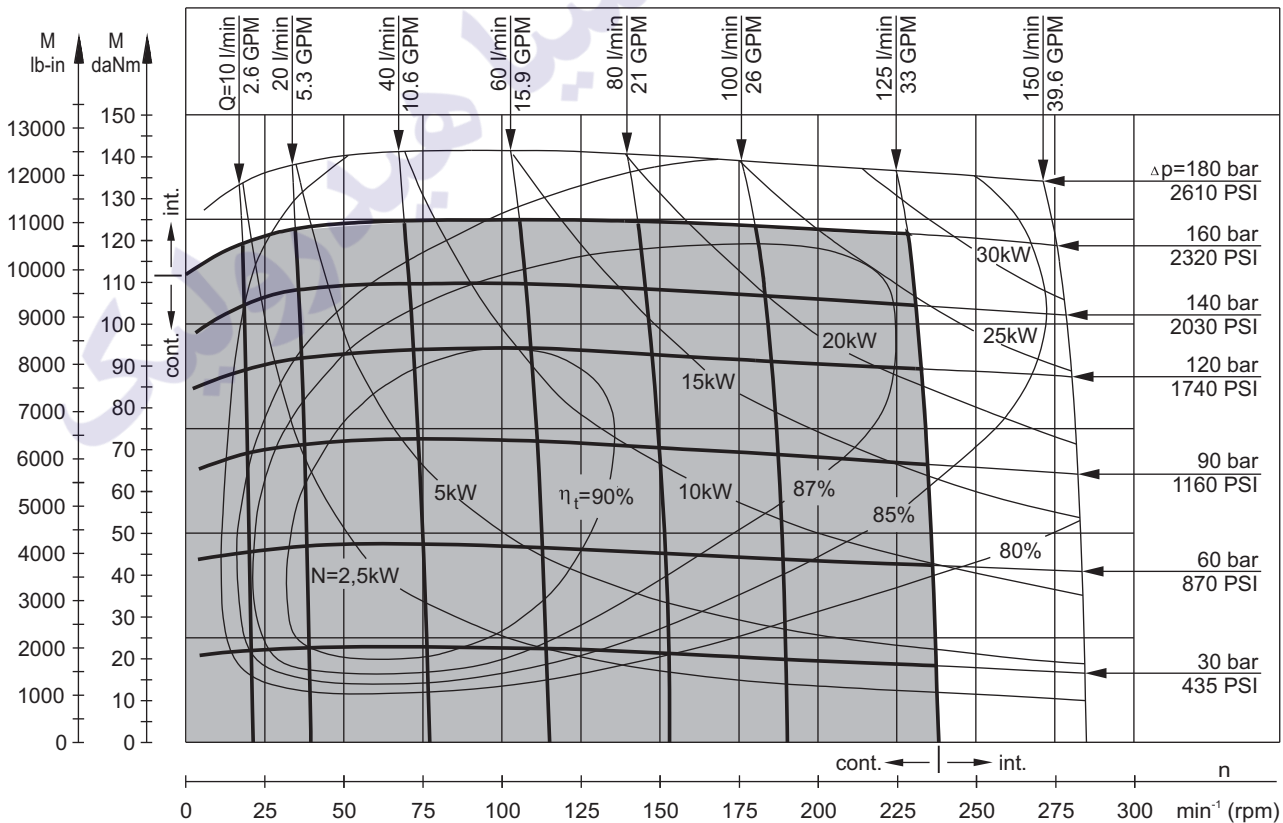

The function diagrams data is for average performance of randomly selected motors at back pressure $5 \div 10$ bar [72.5 \div 145 PSI] and oil with viscosity of 32 mm²/s [150 SUS] at 50°C [122°F].

FUNCTION DIAGRAMS

MT 630

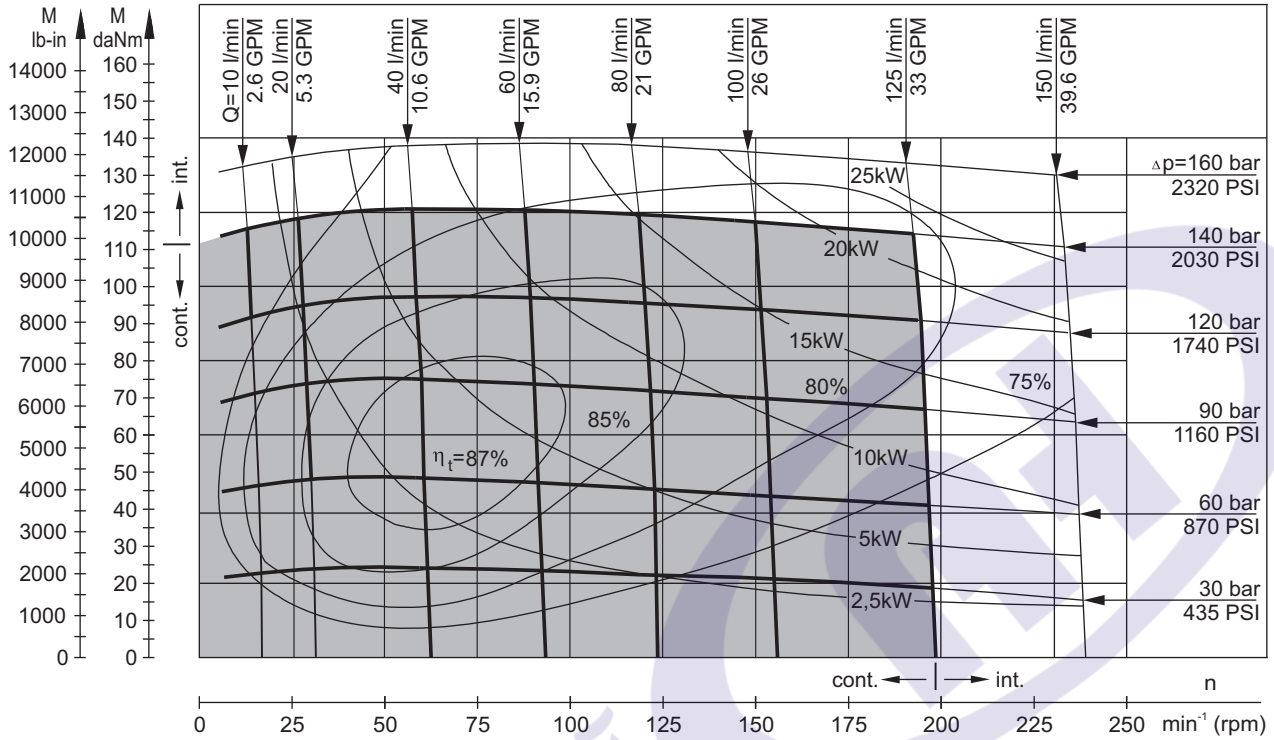

MT 725

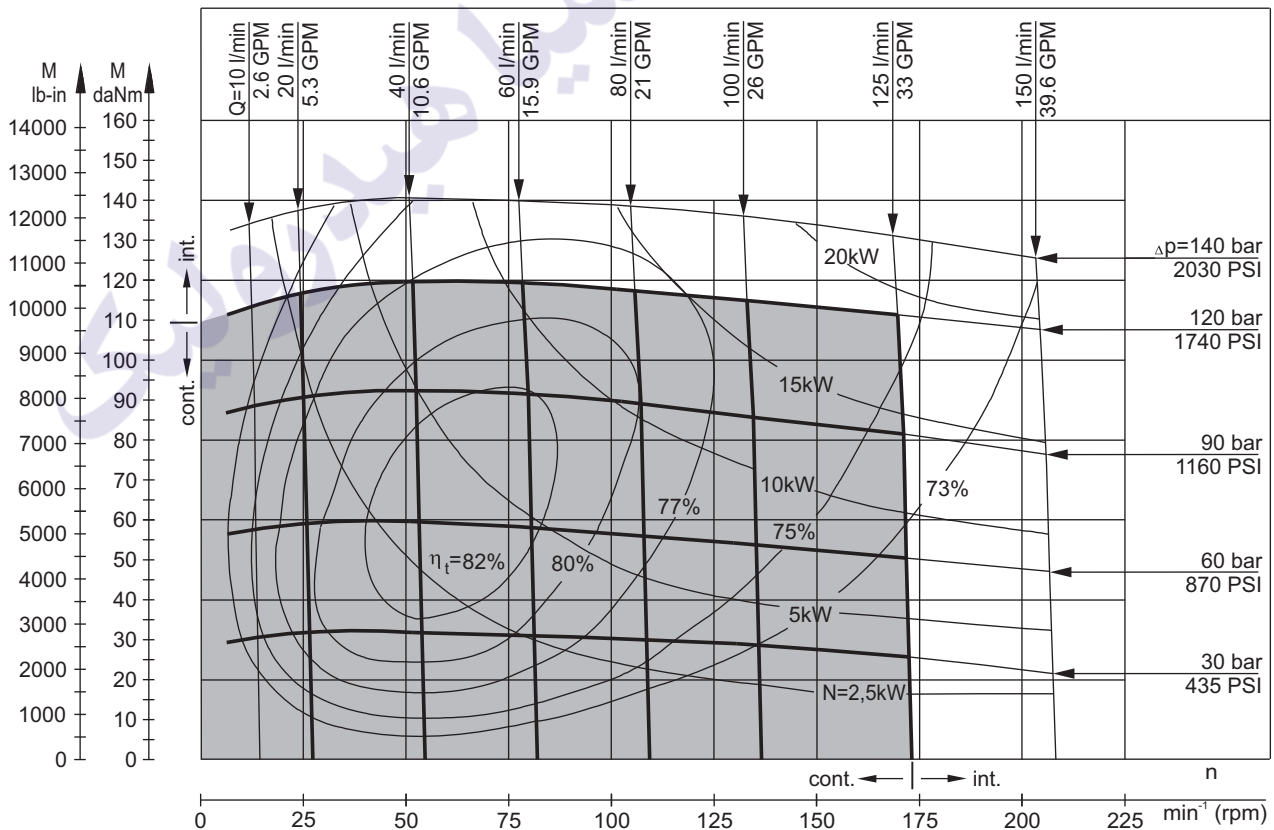

The function diagrams data is for average performance of randomly selected motors at back pressure $5 \div 10$ bar [72.5 ÷ 145 PSI] and oil with viscosity of $32 \text{ mm}^2/\text{s}$ [150 SUS] at 50°C [122°F].

DIMENSIONS AND MOUNTING DATA

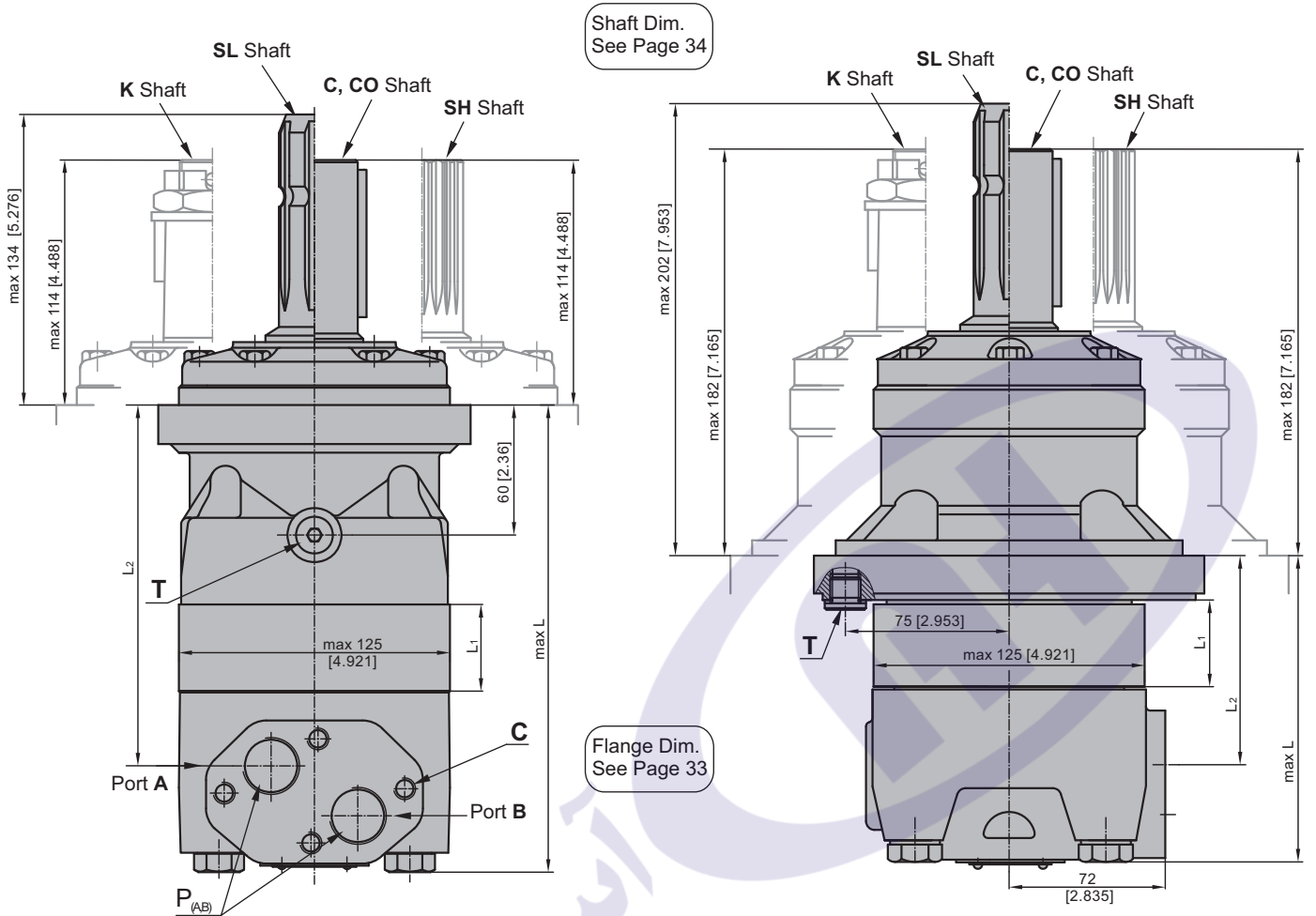

Shaft Dim.
See Page 34

Flange Dim.
See Page 33

Port Dim.
See Page 33

E Rear ports

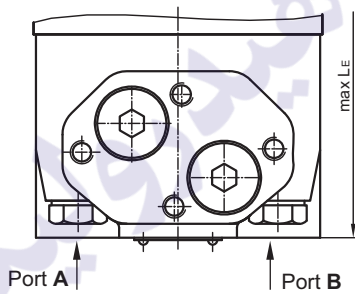

- C** : 4xM10-10 mm [.39 in] depth
- P_(A,B)** : 2xG3/4 or 2xM27x2-17 mm [.67 in] depth
- T** : G 1/4 or M14x1,5 - 12 mm [.47 in] depth (plugged)

Standard Rotation

Viewed from Shaft End
Port A Pressurized - **CW**
Port B Pressurized - **CCW**

Reverse Rotation

Viewed from Shaft End
Port A Pressurized - **CCW**
Port B Pressurized - **CW**

Type	L, mm [in]	L ₂ , mm [in]	**L _E , mm [in]	Type	L, mm [in]	L ₂ , mm [in]	**L _E , mm [in]	*L ₁ , mm [in]
MT 160	193,1 [7.60]	143,5 [5.65]	203,1 [8.00]	MTW 160	124,1 [4.89]	74,3 [2.93]	134,1 [5.28]	16,5 [.65]
MT 200	198,1 [7.80]	148,5 [5.85]	208,1 [8.19]	MTW 200	129,1 [5.08]	79,3 [3.12]	139,1 [5.48]	21,5 [.85]
MT 250	204,4 [8.05]	154,8 [6.09]	214,4 [8.44]	MTW 250	135,4 [5.33]	85,6 [3.37]	145,4 [5.72]	27,8 [1.09]
MT 315	213,6 [8.41]	164,0 [6.46]	223,6 [8.80]	MTW 315	144,6 [5.69]	94,8 [3.73]	154,6 [6.09]	37,0 [1.46]
MT 400	224,1 [8.82]	174,5 [6.87]	234,1 [9.22]	MTW 400	155,1 [6.11]	105,3 [4.15]	165,1 [6.50]	47,5 [1.87]
MT 500	238,1 [9.37]	188,5 [7.42]	248,1 [9.77]	MTW 500	169,1 [6.66]	119,3 [4.70]	179,1 [7.05]	61,5 [2.42]
MT 630	234,1 [9.22]	184,5 [7.26]	244,1 [9.61]	MTW 630	165,1 [6.50]	115,3 [4.54]	175,1 [6.89]	57,5 [2.26]
MT 725	243,1 [9.57]	193,5 [7.62]	253,1 [9.96]	MTW 725	174,1 [6.85]	124,3 [4.89]	184,1 [7.25]	66,5 [2.62]

* - The width of the roll-gerotor is 3,5 mm [.138 in] greater than L₁.

** - For Rear Ported Motors.

MOUNTING

Square Mount (4 Holes)

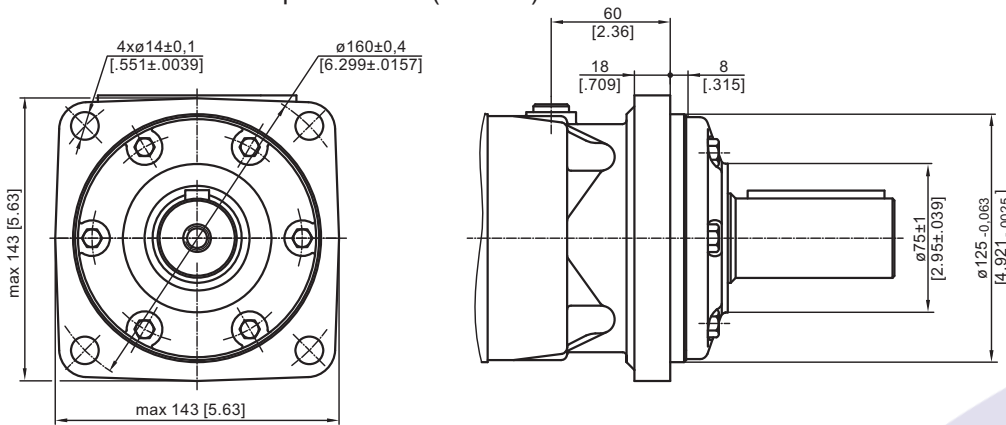

W Wheel Mount

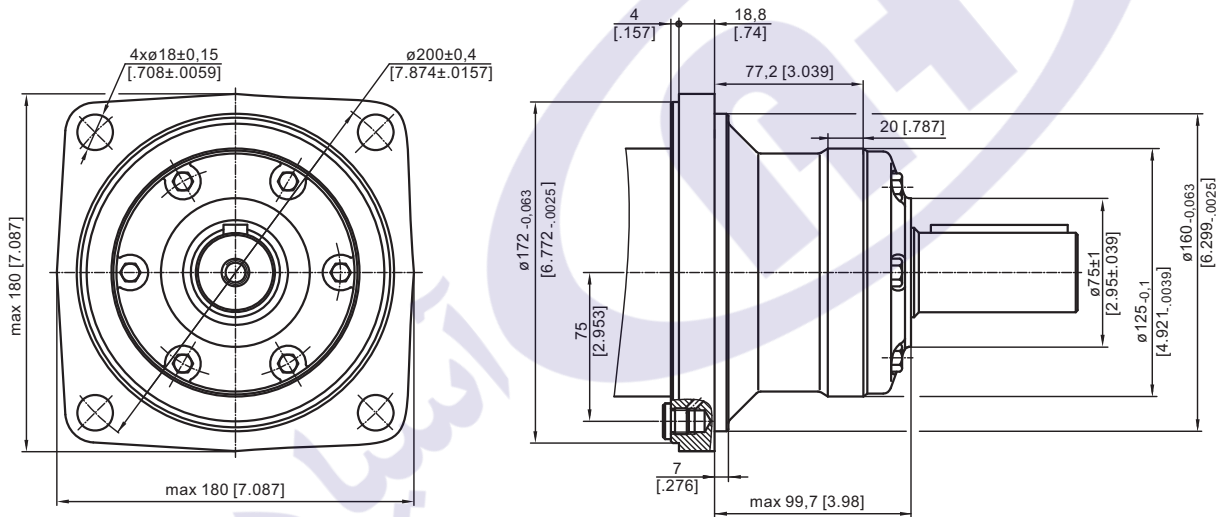

PORTS

Side Ports

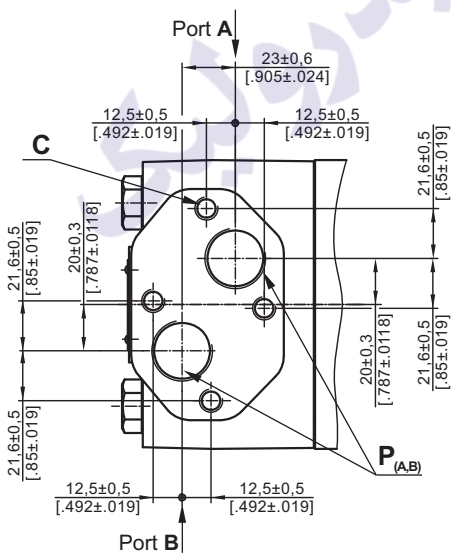

E Rear Ports

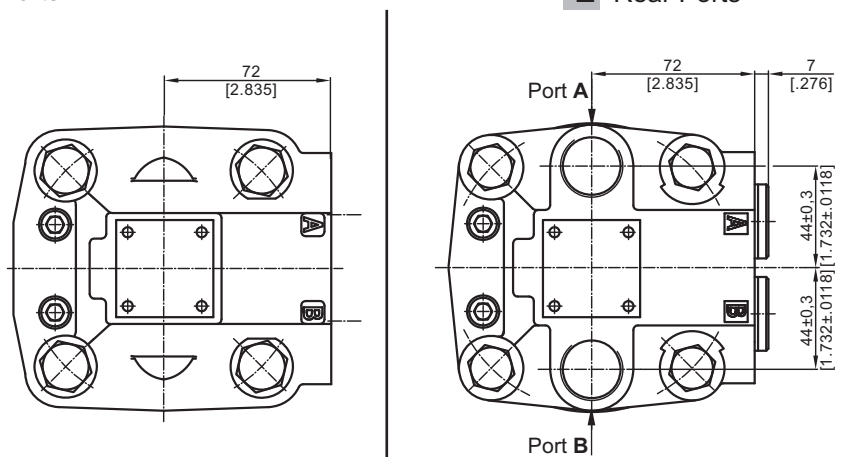

Standard Rotation
Viewed from Shaft End
Port A Pressurized - CW
Port B Pressurized - CCW

Reverse Rotation
Viewed from Shaft End
Port A Pressurized - CCW
Port B Pressurized - CW

C : 4xM10-10 mm [.39 in] depth
P_(A,B) : 2xG3/4 or 2xM27x2-17 mm [.67 in] depth
T : G 1/4 or M14x1,5 - 12 mm [.47 in] depth (plugged)

SHAFT EXTENSIONS

C - ϕ 40 straight, Parallel key A12x8x70 DIN 6885
Max. Torque 132,8 daNm [11755 lb-in]

K -tapered 1:10, Parallel key B12x8x28 DIN 6885
Max. Torque 210,7 daNm [18650 lb-in]

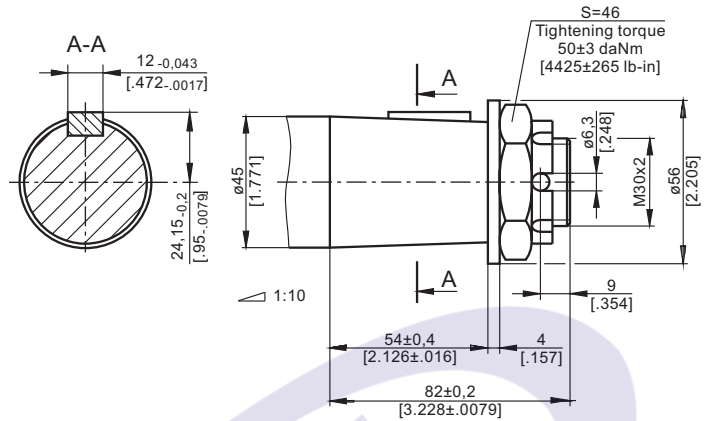
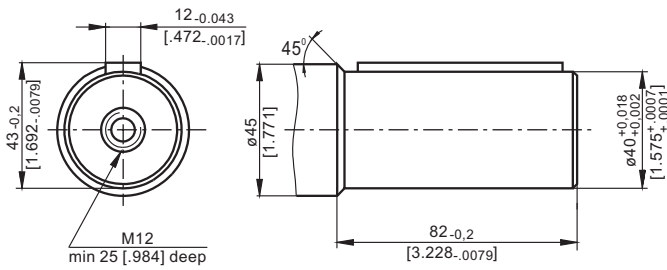

CO - ϕ 1½" straight, Parallel key 3/8" x 3/8" x 2¼" BS46
Max. Torque 132,8 daNm [11755 lb-in]

SH - ϕ 1½" splined 17T, DP 12/24 ANSI B92.1-1976
Max. Torque 132,8 daNm [11755 lb-in]

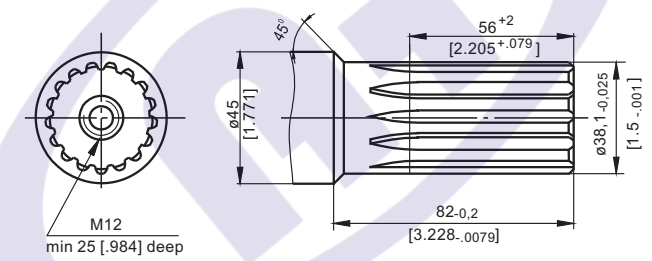
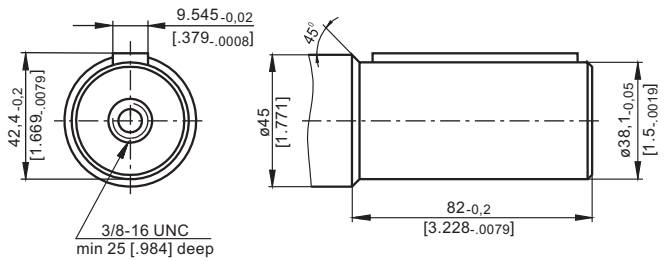

SL - ϕ 34,85 p.t.o. DIN 9611 Form 1
Max. Torque 77 daNm [6815 lb-in]

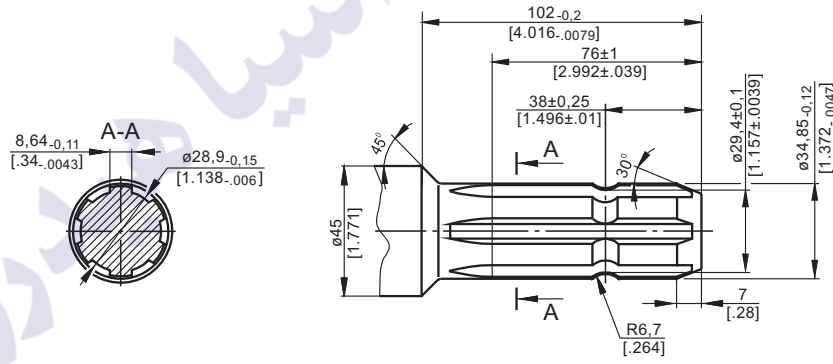

MAX. PERMISSIBLE SHAFT SEAL PRESSURE for MT motors

Max. return pressure without drain line or
max. pressure in the drain line

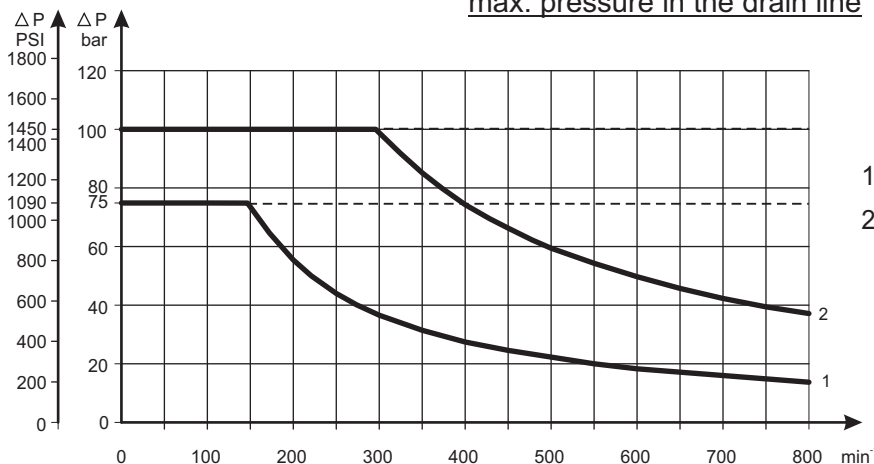

- 1: Drawing for Standard Shaft Seal
- 2: Drawing for High Pressure Seal ("U" Seal)

— - continuous operations
- - - - intermittent operations

DIMENSIONS AND MOUNTING DATA - MTS and MTV

S Short Mount

V Very Short Mount

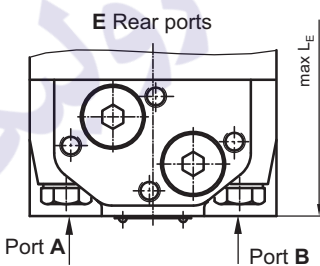
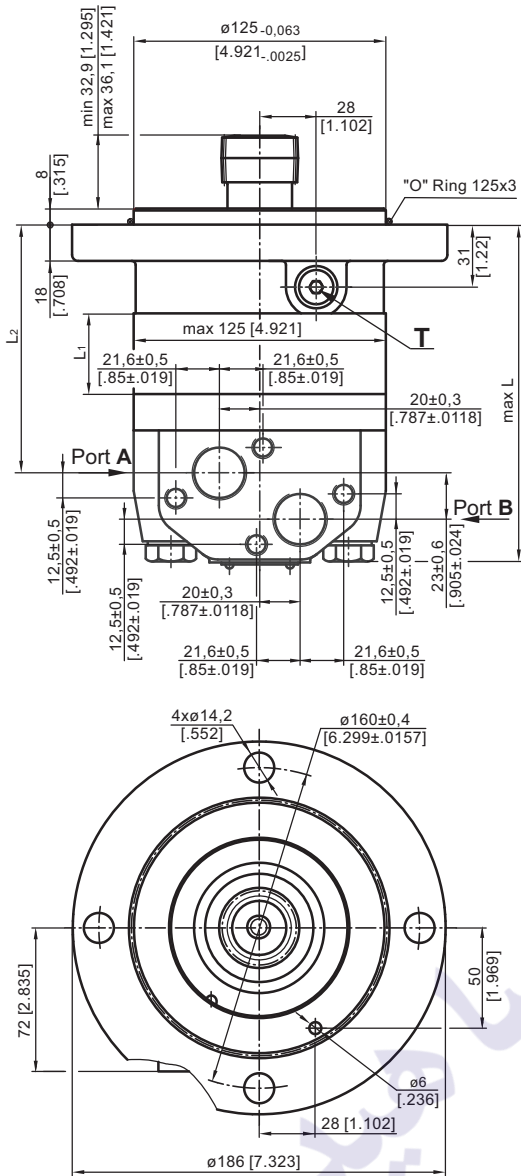

Port Dim.
See Page 33

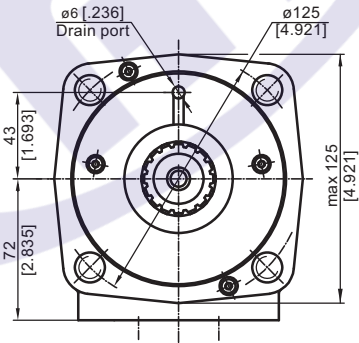
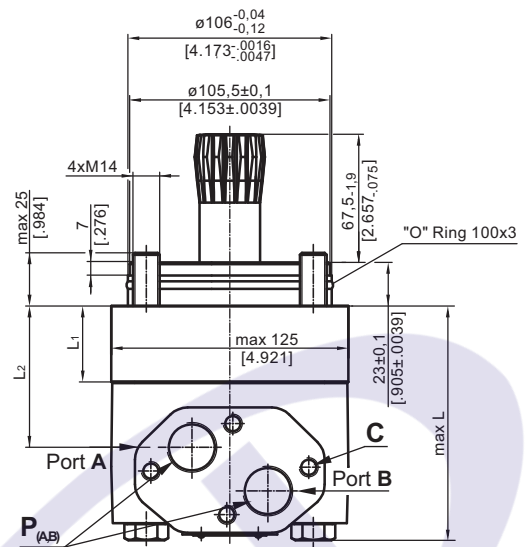

- C:** 4xM10-10 mm [.39 in] depth
- P_(A,B):** 2xG3/4 or 2xM27x2-17 mm [.67 in] depth
- T:** G 1/4 or M14x1,5 - 12 mm [.47 in] depth (plugged)

Standard Rotation

Viewed from Shaft End
Port A Pressurized - **CW**
Port B Pressurized - **CCW**

Reverse Rotation

Viewed from Shaft End
Port A Pressurized - **CCW**
Port B Pressurized - **CW**

Type	L, mm [in]	L ₂ , mm [in]	**L _E , mm [in]	*L ₁ , mm [in]	Type	L, mm [in]	L ₂ , mm [in]	**L _E , mm [in]	*L ₁ , mm [in]
MTS 160	150 [5.90]	103,5 [4.07]	155 [6.10]	20,0 [.79]	MTV 160	100,8 [3.97]	51,5 [2.02]	110,8 [4.36]	16,5 [.65]
MTS 200	155 [6.10]	108,5 [4.27]	160 [6.30]	25,0 [.98]	MTV 200	105,8 [4.17]	56,5 [2.22]	115,8 [4.56]	21,5 [.85]
MTS 250	161 [6.34]	114,8 [4.52]	167 [6.57]	31,3 [1.23]	MTV 250	112,1 [4.41]	62,8 [2.47]	122,1 [4.81]	27,8 [1.09]
MTS 315	170 [6.69]	124,0 [4.88]	176 [6.93]	40,5 [1.59]	MTV 315	121,3 [4.76]	72,0 [2.83]	131,3 [5.17]	37,0 [1.46]
MTS 400	181 [7.13]	134,5 [5.30]	186 [7.32]	51,0 [2.01]	MTV 400	131,8 [5.19]	82,5 [3.25]	141,8 [5.58]	47,5 [1.87]
MTS 500	195 [7.68]	148,5 [5.85]	200 [7.87]	65,0 [2.56]	MTV 500	145,8 [5.74]	96,5 [3.80]	155,8 [6.13]	61,5 [2.42]
MTS 630	191 [7.52]	144,5 [5.69]	196 [7.72]	61,0 [2.40]	MTV 630	141,8 [5.58]	92,5 [3.64]	151,8 [5.98]	57,5 [2.26]
MTS 725	200 [7.87]	153,5 [6.04]	205 [8.07]	70,0 [2.76]	MTV 725	150,8 [5.94]	101,5 [4.00]	160,8 [6.33]	66,5 [2.62]

* - The width of the roll-gerotor is 3,5 mm [.138 in] greater than L₁.

** - For Rear Ported Motors.

DIMENSIONS OF THE ATTACHED COMPONENT

MTS

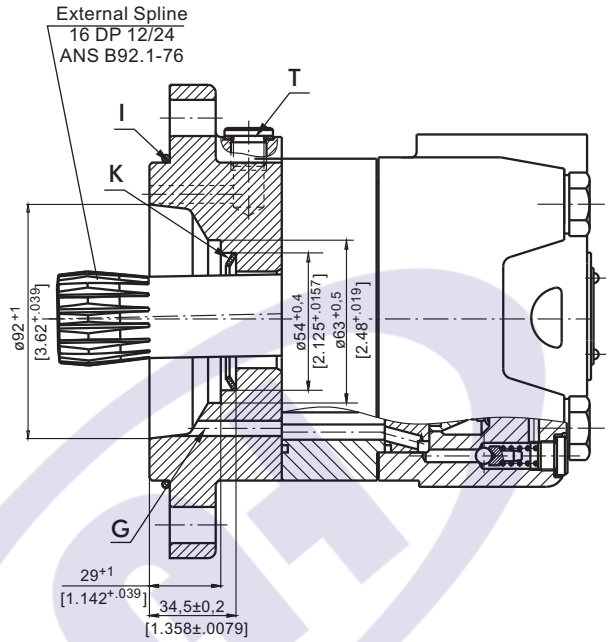
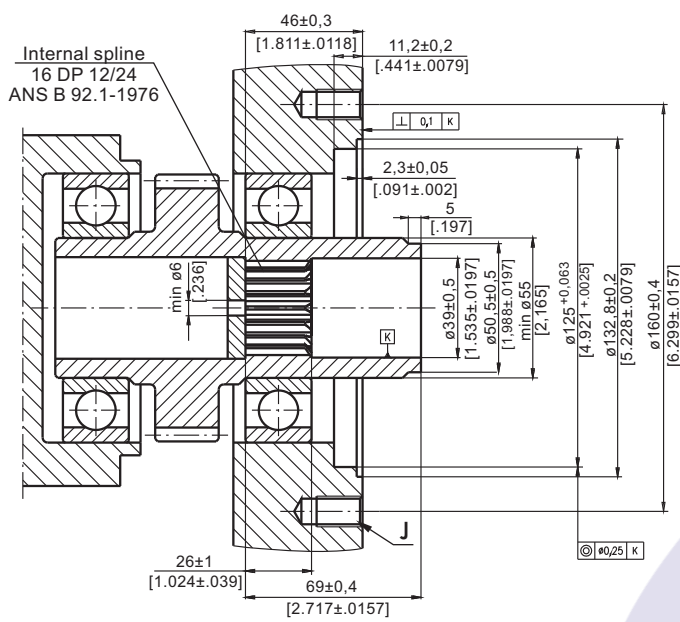

- F: Oil circulation hole
- G: Internal drain channel
- H: Hardened stop plate

- I: O- Ring 125x3 mm [4.921x.118 in]
- J: 4xM12-18 mm [.71 in] depth, 90°
- K: Conical seal ring
- T: Drain connection G1/4 or M14x1,5



MTV

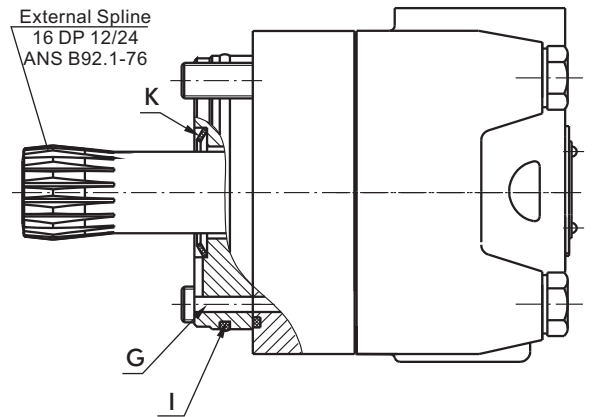
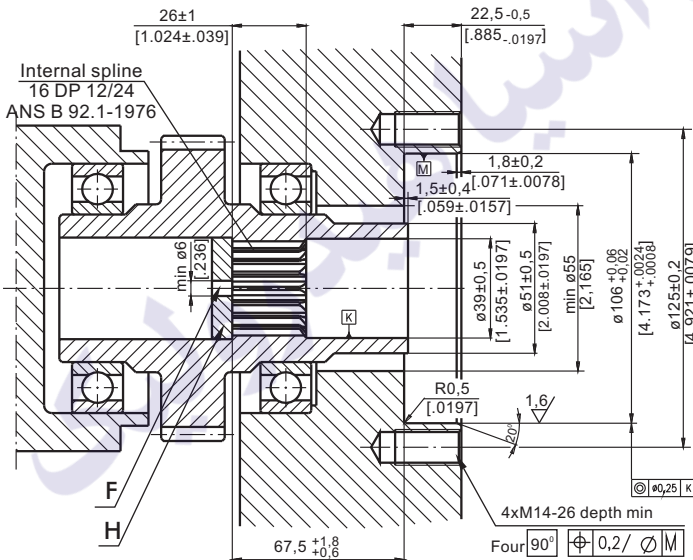

- F: Oil circulation hole
- G: Internal drain channel

- H: Hardened stop plate
- I : O- Ring 100x3 mm [3.94x.12 in]
- K: Conical seal ring

DRAIN CONNECTION

The drain line has to be used when pressure in the return line can exceed the permissible pressure. It can be connected:

- For MTS at the drain port of the motor;
- For MTV at the drain connection of the attached component. The maximum pressure in the drain line is limited by the attached component and its shaft seal.

The drain line must be possible for oil to flow freely between motor and attached component and must be led to the tank. The maximum pressure in the drain line is limited by the attached component and its seal.

INTERNAL SPLINE DATA FOR THE ATTACHED COMPONENT

Standard ANS B92.1-1976, class 5
[m=2.1166; corrected x.m=1]

Flat Root Side Fit		mm	inch
Number of Teeth	z	16	16
Diametral Pitch	DP	12/24	12/24
Pressure Angle		30°	30°
Pitch Dia.	D	33,8656	1.3333
Major Dia.	Dri	38,4 ^{+0,4}	1.5118±1.5275
Minor Dia.	Di	32,15 ^{+0,04}	1.2657±1.2673
Space Width [Circular]	Lo	4,516±0,037	.1763±.1791
Fillet Radius	R	0,5	.02
Max. Measurement between Pins	L	26,9 ^{+0,10}	1.063±1.059
Pin Dia.	d	4,835±0,001	.19026±.19034

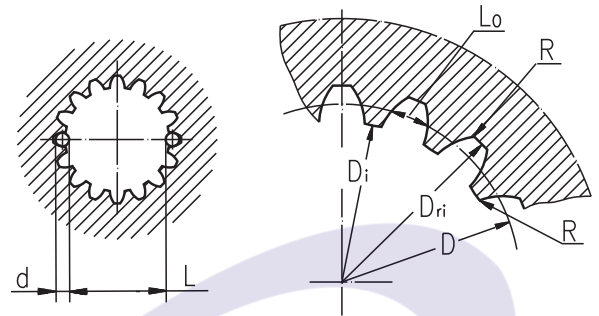

Hardening Specification:
HV=750±50 on the surface.
HV=560 at 0,7±0,2 mm [.035±.019in] case depth
Material: 20 MoCr4 EN 10084 or SAE8620.

PERMISSIBLE SHAFT LOADS

The output shaft runs in tapered bearings that permit high axial and radial forces. The permissible radial load on the shaft is shown for an axial load of 0 N as function of the distance from the mounting flange to the point of load application. The curves apply to a B10 bearing life of 2000 hours at 100 RPM .

Curve "1" shows max. radial shaft load. Any shaft load exceeding the values shown by the curve will seriously reduce motor life.

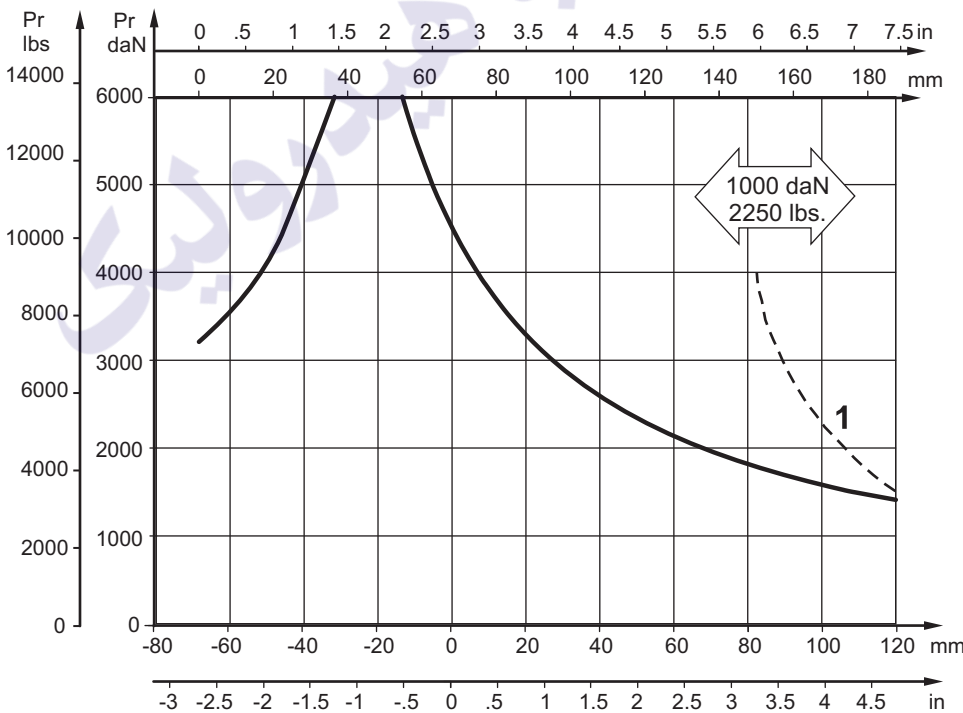

Mounting Flange:

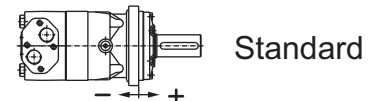

MOTORS WITH TACHO CONNECTION

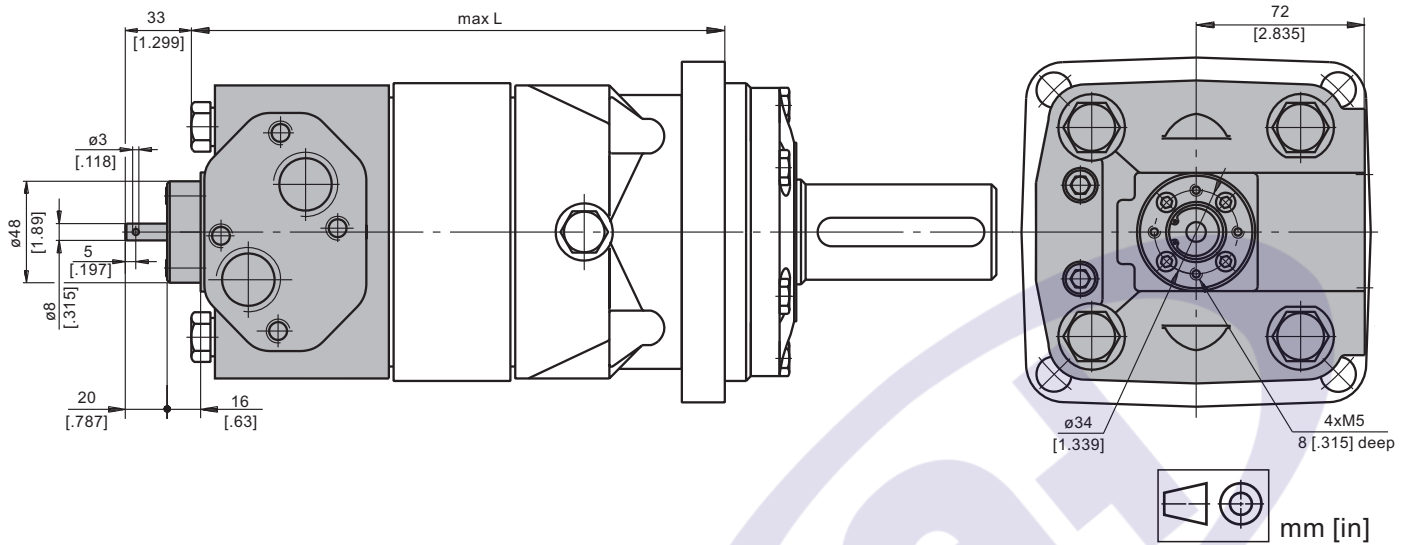

ORDER CODE

	1	2	3	4	5	6	7	8
MT								

Pos.1 - Mounting Flange

omit - Square mount, four holes

S - Short mount

V - Very short mount

W - Wheel mount

Pos.2 - Port type

omit - Side ports

E - Rear ports

Pos.3 - Displacement code

160 - 61,6 cm³/rev [9.83 in³/rev]

200 - 201,4 cm³/rev [12.29 in³/rev]

250 - 251,8 cm³/rev [15.36 in³/rev]

315 - 326,3 cm³/rev [19.90 in³/rev]

400 - 410,9 cm³/rev [25.06 in³/rev]

500 - 523,6 cm³/rev [31.95 in³/rev]

630 - 631,2 cm³/rev [38.52 in³/rev]

725 - 724,3 cm³/rev [44.20 in³/rev]

Pos.4 - Shaft Extensions*

omit - for **S** and **V** mounting flange

C - ø40 straight, Parallel key A12x8x70 DIN6885

CO - ø1½" straight, Parallel key 3/8"x3/8"x2¼" BS46

K - ø45 tapered 1:10, Parallel key B12x8x28 DIN6885

SL - ø34,85 p.t.o. DIN 9611 Form 1

SH - ø1½" splined 17T ANS B92.1-1976

Pos.5 - Shaft Seal Version (see page 34)

omit - Low pressure seal

U - High pressure seal

Pos.6 - Ports

omit - BSPP (ISO 228)

M - Metric (ISO 262)

Pos.7 - Special Features (see page 51)

Pos.8 - Design Series

omit - Factory specified

NOTES:

* The permissible output torque for shafts must not be exceeded!

The hydraulic motors are mangano-phosphatized as standard.