

HYDRAULIC MOTOR-BRAKE MT_{M/B}

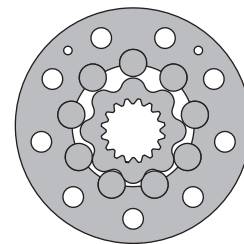

APPLICATION

- » Skid Steer Loaders
- » Metal working machines
- » Trenchers
- » Augers
- » Agricultural machines
- » Road building machines
- » Special vehicles
- » Mine machines
- » Woodworking and sawmill machinery
- » Conveyors etc.



CONTENTS

Specification data	36
Dimensions and mounting ..	37+38
Shaft extensions	39
Permissible shaft loads	40
Order code	40

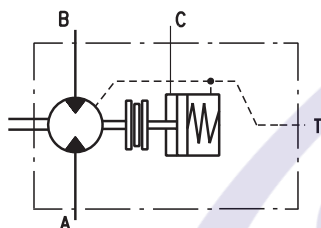

OPTIONS

- » Model - Disc valve, roll-gerotor;
- » Fully integrated friction disk brake;
- » Side ports;
- » Shafts - straight, splined and tapered;
- » BSPP ports
- » Other special features

GENERAL

Max. Displacement, cm ³ /rev [in ³ /rev]	724,3 [44.2]
Max. Speed, [RPM]	750
Max. Torque, daNm [in-lb]	cont.: 175 [15490] int.: 215 [16030]
Max. Output, kW [HP]	70 [94]
Max. Pressure Drop, bar [PSI]	cont.: 250 [3600] int.: 350 [5080]
Max. Oil Flow, lpm [GPM]	150 [40]
Permissible Shaft Loads daN [lbs]	P _a =1000 [2250]
Pressure fluid	Mineral based- HLP(DIN 51524) or HM(ISO 6743/4)
Temperature range, °C [°F]	-40÷140 [-40÷284]
Optimal Viscosity range, mm ² /s [SUS]	20÷75 [98+347]
Filtration	ISO code 20/16 (Min. recommended fluid filtration of 25 microns)

Oil flow in drain line

Pressure drop bar [PSI]	Viscosity mm ² /s [SUS]	Oil flow in drain line lpm [GPM]
200 [2900]	20 [98]	2,5 [.660]
	35 [164]	1,5 [.400]
275 [3990]	20 [98]	4 [1.057]
	35 [164]	2,5 [.660]

Pressure Losses

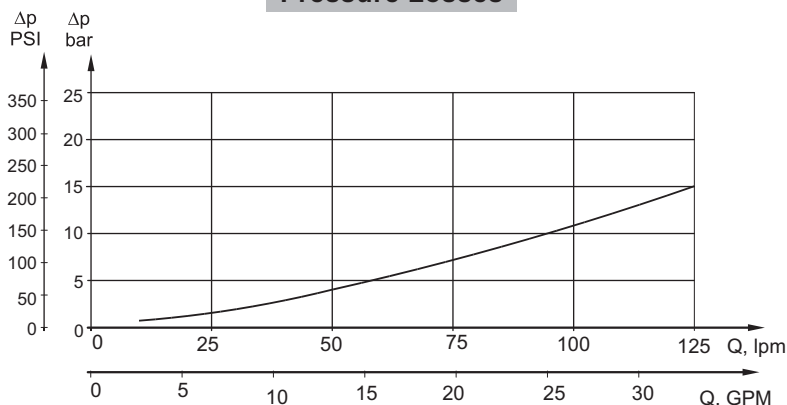

SPECIFICATION DATA

Type	MTM/B 200	MTM/B 250	MTM/B 315	MTM/B 400	MTM/B 470	MTM/B 500	MTM/B 630	MTM/B 725	
Displacement, cm³/rev [in³/rev]	201,4 [12.29]	251,8 [15.36]	326,3 [19.9]	410,9 [25.06]	475 [28.97]	494,9 [30.17]	631,2 [38.5]	724 [44.2]	
Max. Speed, [RPM]	Cont.	625	500	380	305	260	250	196	170
	Int.*	750	600	460	365	315	300	235	215
Max. Torque, daNm [lb-in]	Cont.	72 [6375]	90 [7965]	116 [10265]	147 [13010]	171 [15135]	172 [15225]	175 [15490]	160 [14160]
	Int.*	102 [9030]	128 [11330]	163 [14425]	206 [18232]	215 [16030]	215 [16030]	215 [16030]	192 [17000]
	Peak**	115 [10180]	144 [12745]	186 [16460]	235 [20800]	240 [21240]	240 [21240]	255 [22570]	240 [21240]
Max. Output, kW [HP]	Cont.	41 [55]	41 [55]	41 [55]	41 [55]	41 [55]	37,5 [50]	29 [39]	26 [35]
	Int.*	65 [87]	70 [94]	70 [94]	70 [94]	55 [74]	51 [68]	45 [60]	40 [54]
Max. Pressure Drop, bar [PSI]	Cont.	250 [3600]	250 [3600]	250 [3600]	250 [3600]	250 [3600]	230 [3340]	185 [2680]	160 [2320]
	Int.*	350 [5080]	350 [5080]	350 [5080]	350 [5080]	315 [4570]	280 [4060]	225 [3260]	210 [3045]
	Peak**	400 [5800]	400 [5800]	400 [5800]	400 [5800]	350 [5080]	320 [4640]	270 [3985]	260 [3770]
Max. Oil Flow, lpm [GPM]	Cont.	125 [33]	125 [33]	125 [33]	125 [33]	125 [33]	125 [33]	125 [33]	125 [33]
	Int.*	150 [40]	150 [40]	150 [40]	150 [40]	150 [40]	150 [40]	150 [40]	150 [40]
Max. Starting Pressure with Unloaded Shaft, bar [PSI]	6 [87]	6 [87]	6 [87]	6 [87]	6 [87]	6 [87]	6 [87]	6 [87]	
Min. Starting Torque, daNm [lb-in]	60 [5310]	75 [6640]	97 [8585]	122 [10800]	142 [12570]	143 [12655]	144 [12745]	148 [13100]	
Static Torque of Brake, daNm [lb-in]	200 [17700]								
Min. Brake Release Pressure***, bar [PSI]	14 [203]								
Full Opening Pressure, bar [PSI]	40 [580]								
Max. Pressure in Release Port C, bar [PSI]	120 [1740]								
Weight, kg [lb]	37,5 [82.7]	37,9 [83.6]	39,1 [86.2]	41,3 [91.1]	44,1 [97.2]	46,0 [101.4]	49,1 [108.2]	52,0 [114.6]	

* Intermittent operation: the permissible values may occur for max. 10% of every minute.

** Peak load: the permissible values may occur for max. 1% of every minute.

*** Motor-brakes must always have a drain line. The brake release pressure is the difference between the pressure in the brake release line and the pressure in the drain line.

- Intermittent speed and intermittent pressure drop must not occur simultaneously.
- Recommended filtration is per ISO cleanliness code 20/16. A nominal filtration of 25 micron or better.
- Recommend using a premium quality, anti-wear type mineral based hydraulic oil HLP(DIN51524) or HM (ISO 6743/4). If using synthetic fluids consult the factory for alternative seal materials.
- Recommended minimum oil viscosity 13 mm²/s [70 SUS] at 50°C [122°F].
- Recommended maximum system operating temperature is 82°C [180°F].
- To assure optimum motor life fill with fluid prior to loading and run at moderate load and speed for 10-15 minutes.

DIMENSIONS AND MOUNTING DATA - MTM/B D

D - Bolt flange 4xø18.5 mm
spigot diameter 7.086 in [ø180 mm]

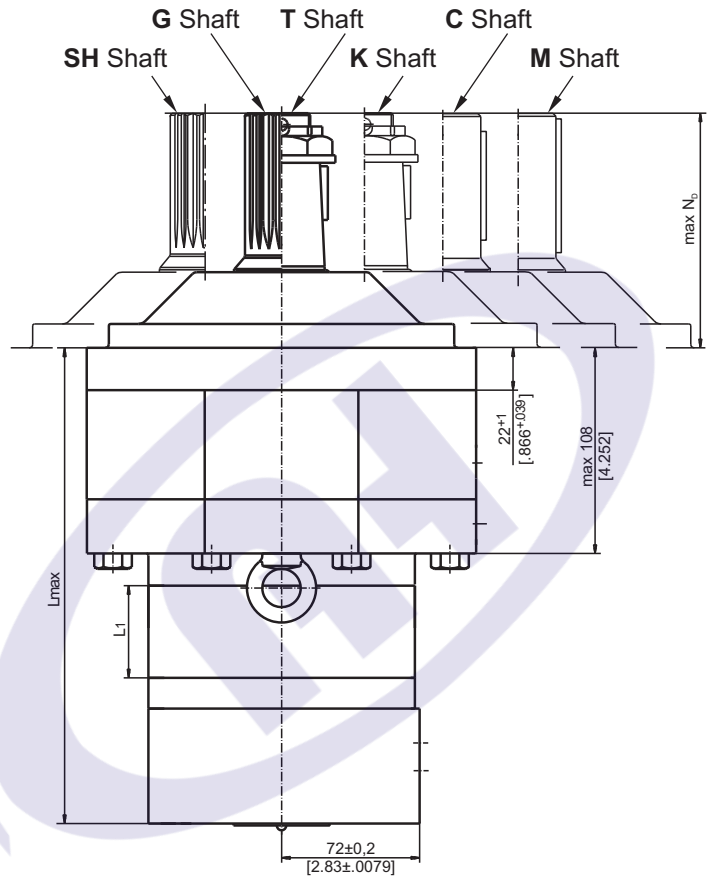
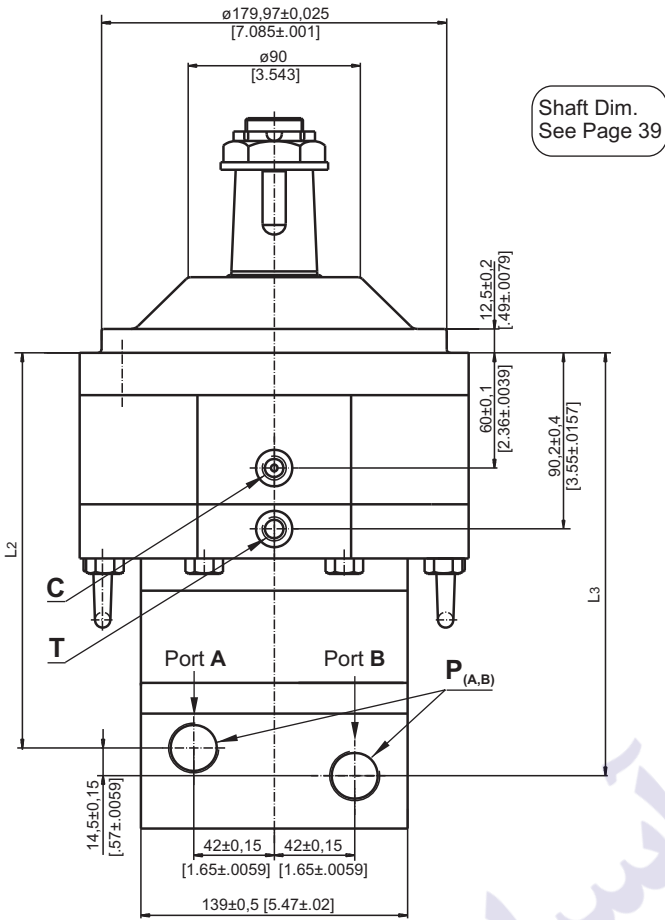

Standard Rotation
Viewed from Shaft End
Port **A** Pressurized - **CW**
Port **B** Pressurized - **CCW**

Reverse Rotation
Viewed from Shaft End
Port **A** Pressurized - **CCW**
Port **B** Pressurized - **CW**

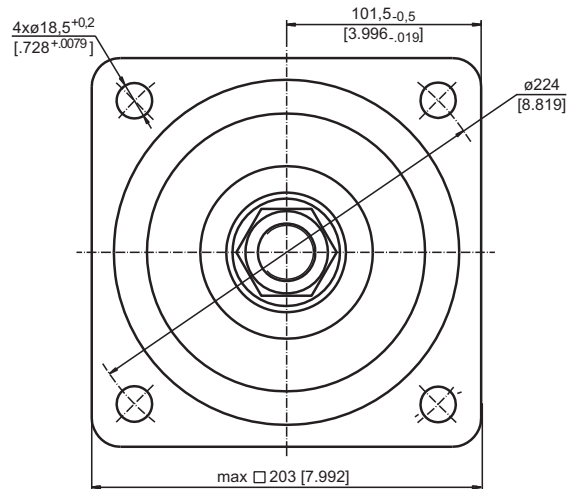

Type	L, mm [in]	L2, mm [in]	L3, mm [in]	L1, mm [in]
MTM/B D 200	226 [8.90]	184 [7.24]	198,5 [7.86]	25 [.98]
MTM/B D 250	232,5 [9.15]	190 [7.48]	204,5 [8.05]	31,3 [1.23]
MTM/B D 315	241,5 [9.51]	199,5 [7.85]	214 [8.43]	40,5 [1.59]
MTM/B D 400	252 [9.92]	210 [8.27]	224,5 [8.84]	51 [2.01]
MTM/B D 470	260 [10.24]	218 [8.58]	232,5 [9.15]	59 [2.32]
MTM/B D 500	249 [9.80]	207 [8.15]	221,5 [8.72]	48 [1.89]
MTM/B D 630	262 [10.32]	220 [8.66]	234,5 [9.23]	61 [2.40]
MTM/B D 725	271 [10.67]	229 [9.02]	243,5 [9.59]	70 [2.76]

Note: For N_b see page 39

C : Brake release port
T : Drainage tap

	Versions	
	2	4
P (A,B)	2xG ³ / ₄	2x1 ¹ / ₁₆ -12UN
T	G ¹ / ₄	⁹ / ₁₆ -18UNF
C	G ¹ / ₄	⁷ / ₁₆ -20 UNF

DIMENSIONS AND MOUNTING DATA MTM/B C and MTM/B AC

C - Thread hole flange 4xM16
spigot diameter 125 mm [4.921 in]

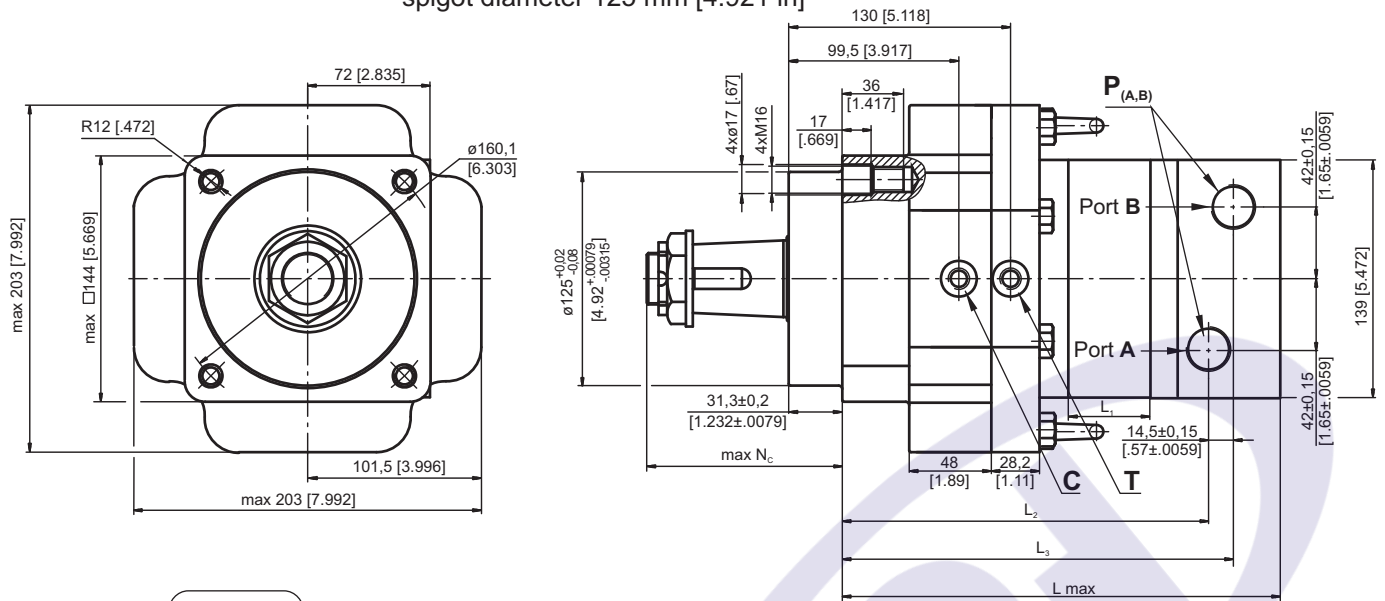

Shaft Dim.
See Page 39

AC - Thread hole flange 4x5/8-18 UNF
spigot diameter 127 mm [5.0 in]

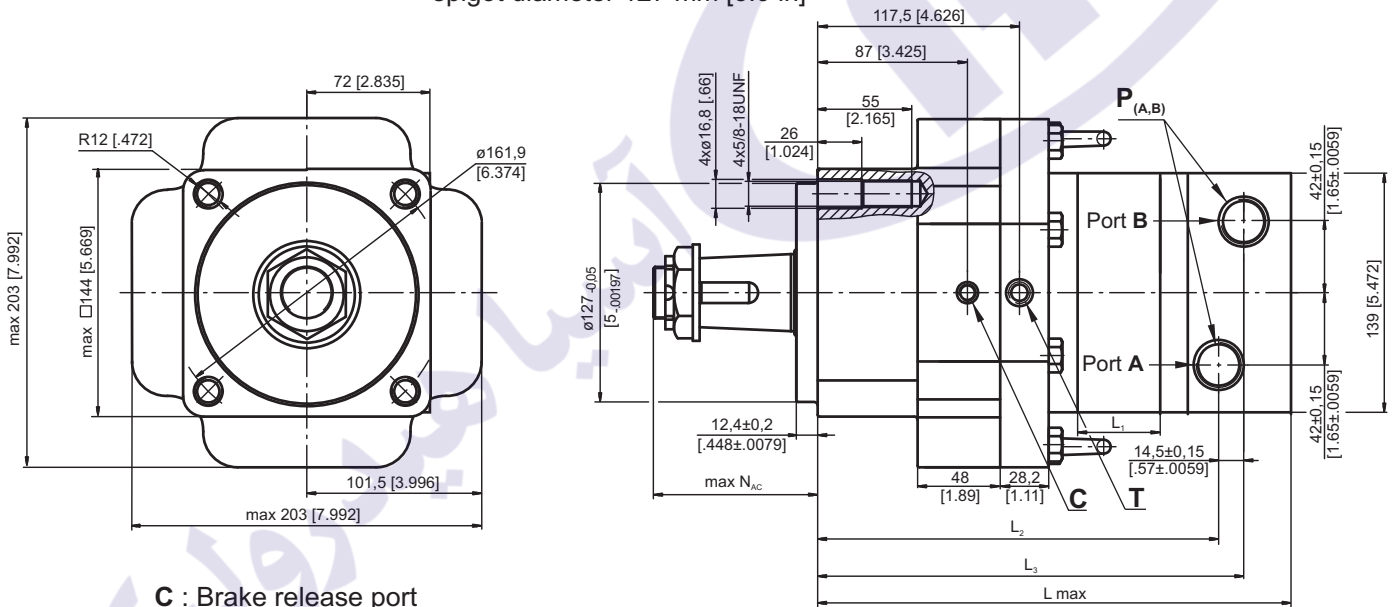

C : Brake release port
T : Drainage tap

	Versions	
	2	4
P (A,B)	2xG ³ / ₄	2x1 ¹ / ₁₆ -12UN
T	G ¹ / ₄	9 ¹ / ₁₆ -18UNF
C	G ¹ / ₄	7 ¹ / ₁₆ -20 UNF

Note: For N_C and N_{AC} see page 39

Standard Rotation
Viewed from Shaft End
Port A Pressurized - **CW**
Port B Pressurized - **CCW**

Reverse Rotation
Viewed from Shaft End
Port A Pressurized - **CCW**
Port B Pressurized - **CW**



Type	L, mm [in]	L2, mm [in]	L3, mm [in]	Type	L, mm [in]	L2, mm [in]	L3, mm [in]	L1, mm [in]
MTM/B C 200	233 [9.17]	191 [7.92]	205,5 [8.09]	MTM/B AC 200	252 [9.92]	210 [8.27]	224,5 [8.84]	25 [0.98]
MTM/B C 250	239,3 [9.42]	197,3 [7.77]	211,8 [8.34]	MTM/B AC 250	258,5 [10.18]	216,5 [8.25]	231 [9.09]	31,3 [1.23]
MTM/B C 315	248,5 [9.48]	206,5 [8.13]	221 [8.70]	MTM/B AC 315	267,5 [10.53]	225,5 [8.88]	240 [9.45]	40,5 [1.59]
MTM/B C 400	259 [10.19]	217 [8.54]	231,5 [9.11]	MTM/B AC 400	278 [10.94]	236 [9.29]	250,5 [9.186]	51 [2.01]
MTM/B C 470	267 [10.51]	225 [8.86]	239,5 [9.43]	MTM/B AC 470	286 [11.26]	244 [9.61]	258,5 [10.18]	59 [2.32]
MTM/B C 500	256 [10.08]	214 [8.43]	228,5 [8.99]	MTM/B AC 500	275 [10.83]	233 [9.17]	247,5 [9.74]	48 [1.89]
MTM/B C 630	269 [10.59]	227 [8.94]	241,5 [9.51]	MTM/B AC 630	288 [11.34]	246 [9.68]	260,5 [10.26]	61 [2.40]
MTM/B C 725	278 [10.94]	236 [9.29]	250,5 [9.86]	MTM/B AC 725	297 [11.69]	255 [10.04]	269,5 [10.61]	70 [2.76]

SHAFT EXTENSIONS

C

1½" [38,1] sraight, Parallel key ¾"x ¾"x 2¼" BS46
Max. Torque 133 daNm [11770 lb-in]

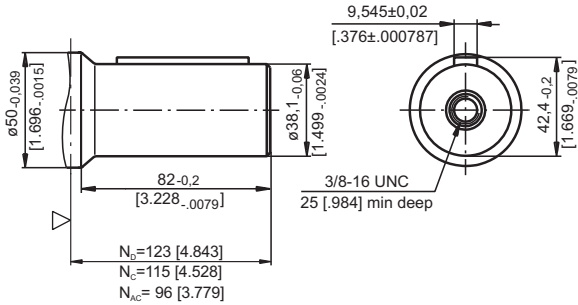

M

ø40 sraight, Parallel key A12x8x70
Max. Torque 133 daNm [11770 lb-in]

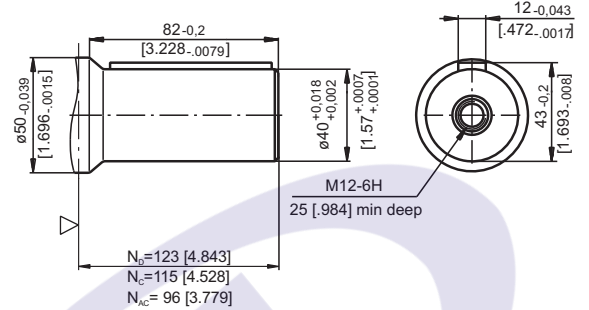

G

17T Splined, 1½" [38,1] ANS B92.1-1976
Max. Torque 210 daNm [18580 lb-in]

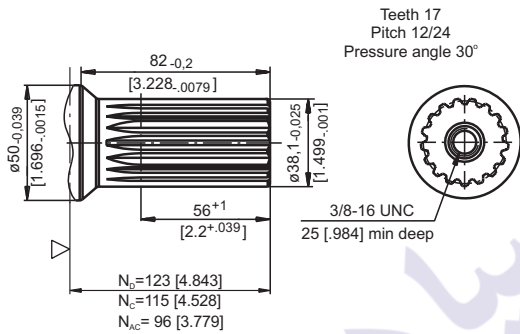

T

1¼" [44,5] SAE J501 Tapered 1:8
Parallel key 7/16"x 1¼" BS46
Max. Torque 210 daNm [18580 lb-in]

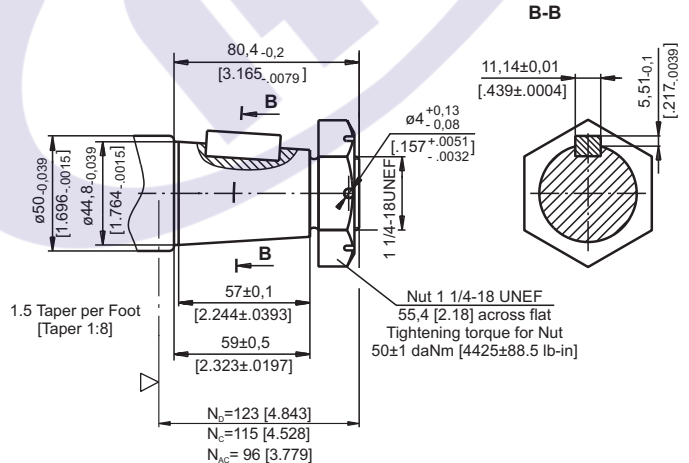

SH

17T Splined, 1½" [38,1] ANS B92.1-1976
Max. Torque 210 daNm [18580 lb-in]

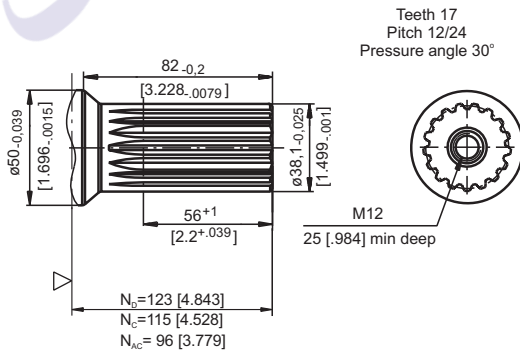

K

ø45 Tapered 1:10
Parallel key 12x8x28 DIN 6885
Max. Torque 210 daNm [18580 lb-in]

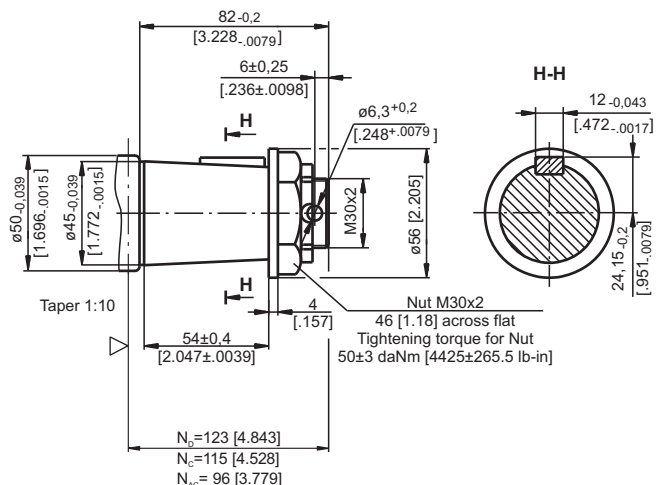

▽ - Motor Mounting Surface

N_D - for D flange
N_C - for C flange
N_{AC} - for AC flange



PERMISSIBLE RADIAL SHAFT LOADS

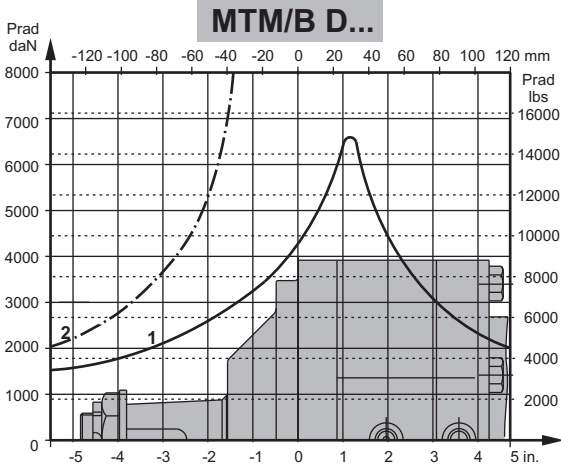

- 1 - Bearing curve: The curve applies to a B10 bearing life of 2000 hours at 100 RPM.
- 2 - Shaft curve: The curve represents Max. permissible radial shaft load with safety factor 2:1.

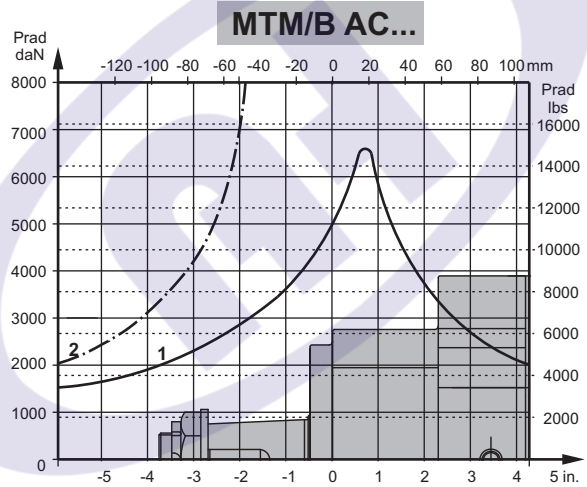
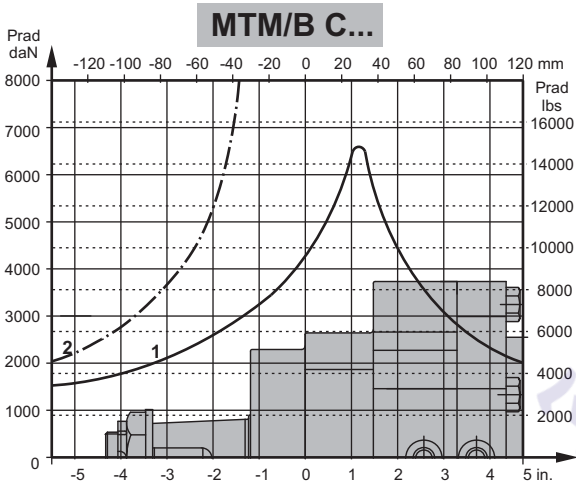

ORDER CODE

1	2	3	4	5	6
MTM/B					

Pos.1 - Mounting Flange

- AC** - Flange 4x5/8-18UNC, spigot dia. \varnothing 127 mm [5 in]
- C** - Flange 4xM16, spigot dia. \varnothing 125 mm [4.92 in]
- D** - Flange 4x \varnothing 18,5 [.73], spigot dia. \varnothing 180 mm [7.09 in]

Pos.2 - Displacement code

- 200** - 201,4 cm³/rev [12.29 in³/rev]
- 250** - 251,8 cm³/rev [15.36 in³/rev]
- 315** - 326,3 cm³/rev [19.90 in³/rev]
- 400** - 410,9 cm³/rev [25.06 in³/rev]
- 470** - 475,0 cm³/rev [28.97 in³/rev]
- 500** - 523,6 cm³/rev [31.95 in³/rev]
- 630** - 631,2 cm³/rev [38.52 in³/rev]
- 725** - 724,3 cm³/rev [44.20 in³/rev]

Pos.3 - Shaft Extensions*

- C** - 1½" [38,1] straight, Parallel key 3/8x3/8x2 1/4"
- G** - 1½" [38,1] 17T Splined (3/8-16 UNC)
- M** - 40 mm straight, Parallel key 12x8x70
- T** - 1:8 Tapered, Parallel key 7/16x7/16x1 1/4"
- SH** - 1½" [38,1] 17T Splined (M12)
- K** - 1:10 Tapered, Parallel key 12x8x28

Pos.4 - Port Size/Type

- 2** - side ports, 2xG 3/4, G1/4, BSP thread, ISO 228
- 4** - side ports, 2x1¹/₁₆-12 UN, O-ring, ⁹/₁₆-18 UNF, 7/16-20UNF

Pos.5 - Special Features

- omit - Reinforced motor **HD**** (always)
- For Other **Special Features** see page 68

Pos.6 - Design Series

- omit - Factory specified

Notes:

- * The permissible output torque for shafts must not be exceeded!
- ** The drain line must always be opened!

The motor-brakes are mangano-phosphatized as standard.