

HYDRAULIC MOTORS MVM

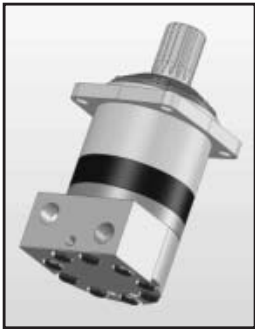

APPLICATION

- » Conveyors
- » Metal working machines
- » Agricultural machines
- » Road building machines
- » Mining machinery
- » Food industries
- » Special vehicles
- » Plastic and rubber machinery etc.

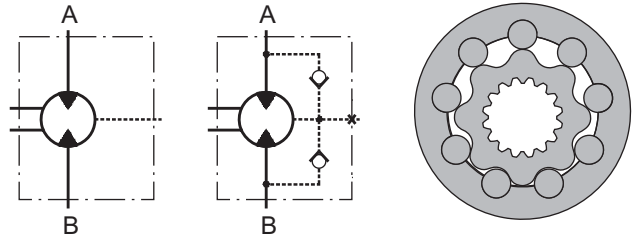

CONTENTS

Specification data	44
Function diagrams	45-47
Dimensions and mounting MVM	48
Mounting Flanges	49
Port Types	49
Shaft extensions	50
Permissible shaft Seal Pressure	51
Order code	51

OPTIONS

- » Model - Disc valve, roll-gerotor
- » Flange with wheel mount
- » Short motor
- » Side ports
- » Shafts - straight, splined and tapered
- » BSPP ports Metric, SAE and BSPP ports;
- » Other special features.

EXCELLENCE

- » High torque and pressure drop
- » High inlet pressure
- » High starting torque
- » Improved efficiency at high pressure drop and frequent reversing
- » Smooth operation at low speed
- » High radial and axial bearing capacity

GENERAL

Max. Displacement, cm ³ /rev [in ³ /rev]	801,8 [48.91]
Max. Speed, [RPM]	763
Max. Torque, daNm [lb-in]	cont.: 259 [22920] int.: 340 [30090]
Max. Output, kW [HP]	112 [150]
Max. Pressure Drop, bar [PSI]	cont.: 250 [3630] int.: 350 [5080]
Max. Oil Flow, lpm [GPM]	240 [63.4]
Min. Speed, [RPM]	5
Permissible Shaft Loads, daN [lbs]	Pa=1500 [3370]
Pressure fluid	Mineral based- HLP(DIN 51524) or HM(ISO 6743/4)
Temperature range, °C [°F]	-40÷140 [-40÷284]
Optimal Viscosity range, mm ² /s [SUS]	20÷75 [98÷347]
Filtration	ISO code 20/16 (Min. recommended fluid filtration of 25 microns)

Oil flow in drain line

Pressure drop bar [PSI]	Viscosity mm ² /s [SUS]	Oil flow in drain line lpm [GPM]
140 [2030]	20 [98]	3 [.793]
	35 [164]	2 [.528]
210 [3045]	20 [98]	6 [1.585]
	35 [164]	4 [1.057]

Pressure Losses

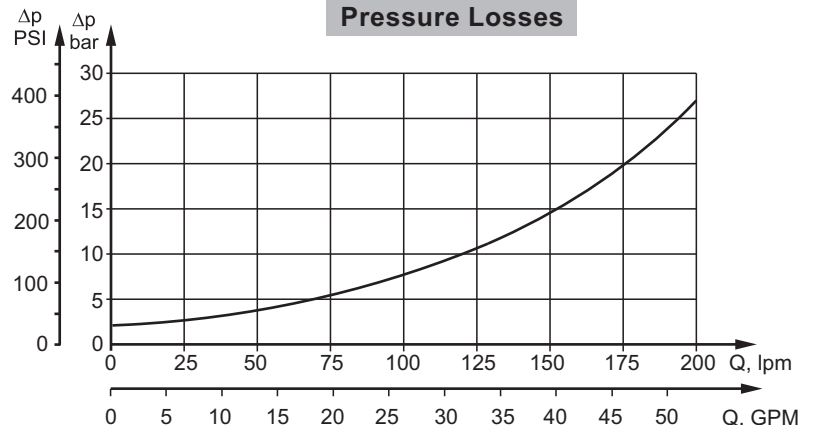

SPECIFICATION DATA

Type		MVM 315	MVM 400	MVM 500	MVM 630	MVM 800
Displacement, cm³/rev [in³/rev]		314,5 [19.19]	400,9 [24.5]	499,6 [30.5]	629,1 [38.38]	801,8 [48.91]
Max. Speed, [RPM]	cont.	636	500	400	315	250
	Int.*	763	600	480	380	300
Max. Torque daNm [lb-in]	cont.	115 [10180]	144 [12745]	180 [15930]	227 [20090]	259 [22920]
	Int.*	160 [14160]	200 [17700]	260 [23010]	310 [27440]	340 [30090]
	peak**	180 [15930]	230 [20355]	286 [25315]	360 [31860]	402 [35580]
Max. Output kW [HP]	cont.	67 [90]	67 [90]	67 [90]	67 [90]	67 [90]
	int.*	112 [150]	112 [150]	112 [150]	112 [150]	112 [150]
Max. Pressure Drop bar [PSI]	cont.	250 [3630]	250 [3630]	250 [3630]	250 [3630]	225 [3263]
	Int.*	350 [5080]	350 [5080]	350 [5080]	350 [5080]	300 [4350]
	peak**	400 [5800]	400 [5800]	400 [5800]	400 [5800]	350 [5080]
Max. Oil Flow lpm [GPM]	cont.	200 [52.8]	200 [52.8]	200 [52.8]	200 [52.8]	200 [52.8]
	Int.*	240 [63.4]	240 [63.4]	240 [63.4]	240 [63.4]	240 [63.4]
Max. Inlet Pressure bar [PSI]	cont.	270 [3915]	270 [3915]	270 [3915]	270 [3915]	270 [3915]
	Int.*	370 [5365]	370 [5365]	370 [5365]	370 [5365]	370 [5365]
	peak**	420 [6090]	420 [6090]	420 [6090]	420 [6090]	420 [6090]
Max. Return Pressure with Drain Line bar [PSI]	cont.	140 [2030]	140 [2030]	140 [2030]	140 [2030]	140 [2030]
	Int.*	175 [2540]	175 [2540]	175 [2540]	175 [2540]	175 [2540]
	peak**	210 [3045]	210 [3045]	210 [3045]	210 [3045]	210 [3045]
Max. Starting Pressure with Unloaded Shaft, bar [PSI]		5 [70]	5 [70]	5 [70]	5 [70]	5 [70]
Min. Starting Torque daNm [lb-in]		92 [8140]	115 [10180]	144 [12745]	180 [15930]	205 [18145]
Min. Speed***, [RPM]		10	6	8	6	5
Weight, kg [lb]	MVM	41,3 [91]	42,1 [93]	43 [95]	44,5 [98]	46 [101.4]
	MVMC	43,8 [96.6]	44,9 [99]	45,8 [101]	48,3 [106.5]	50,4 [111.1]

* Intermittent operation: the permissible values may occur for max. 10% of every minute.

** Peak load: the permissible values may occur for max. 1% of every minute.

*** For speeds lower than given, consult factory or your regional manager.

- Intermittent speed and intermittent pressure must not occur simultaneously.
- Recommended filtration is per ISO cleanliness code 20/16. A nominal filtration of 25 micron or better.
- Recommend using a premium quality, anti-wear type mineral based hydraulic oil HLP(DIN51524) or HM (ISO 6743/4). If using synthetic fluids consult the factory for alternative seal materials.
- Recommended minimum oil viscosity 13 mm²/s [70 SUS] at 50°C [122°F].
- Recommended maximum system operating temperature is 82°C [180°F].
- To assure optimum motor life fill with fluid prior to loading and run at moderate load and speed for 10-15 minutes.

FUNCTION DIAGRAMS

MVM 315

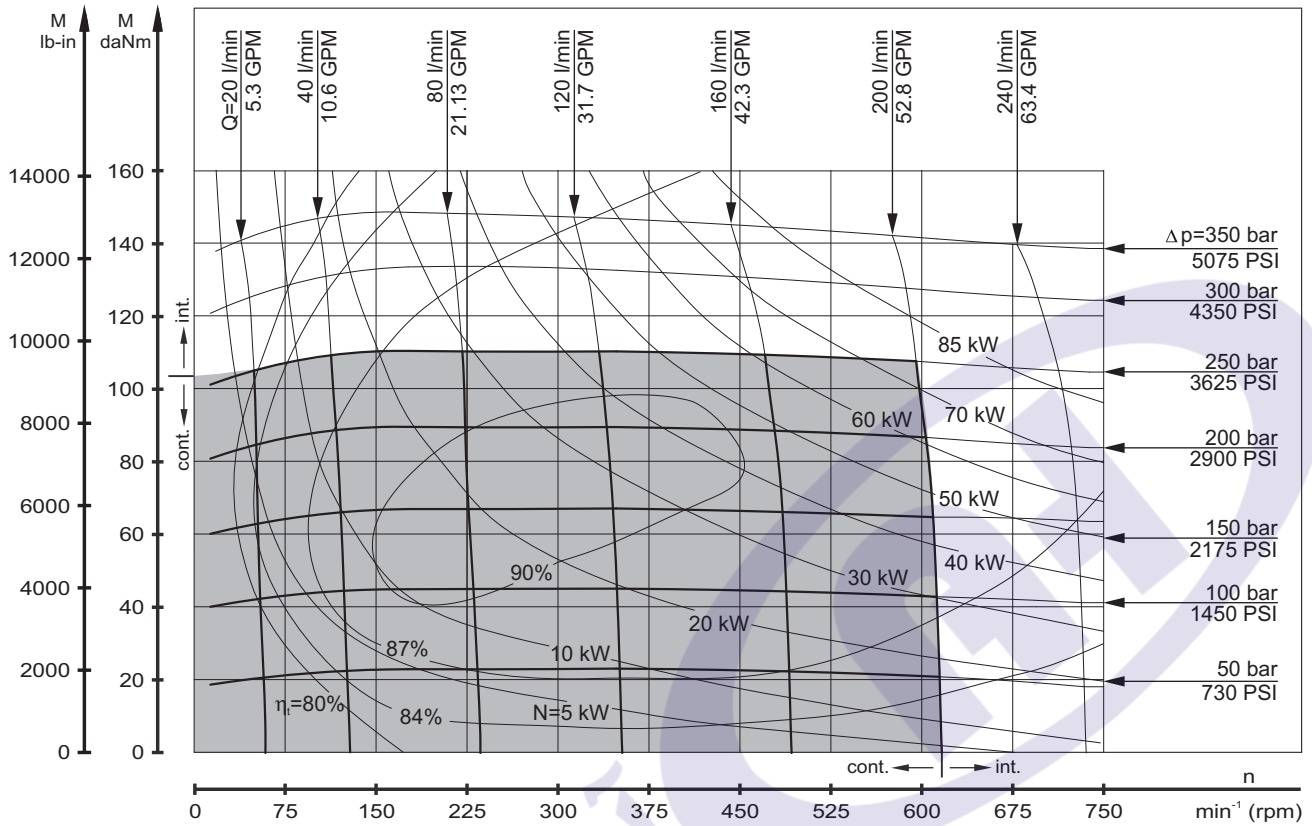

MVM 400

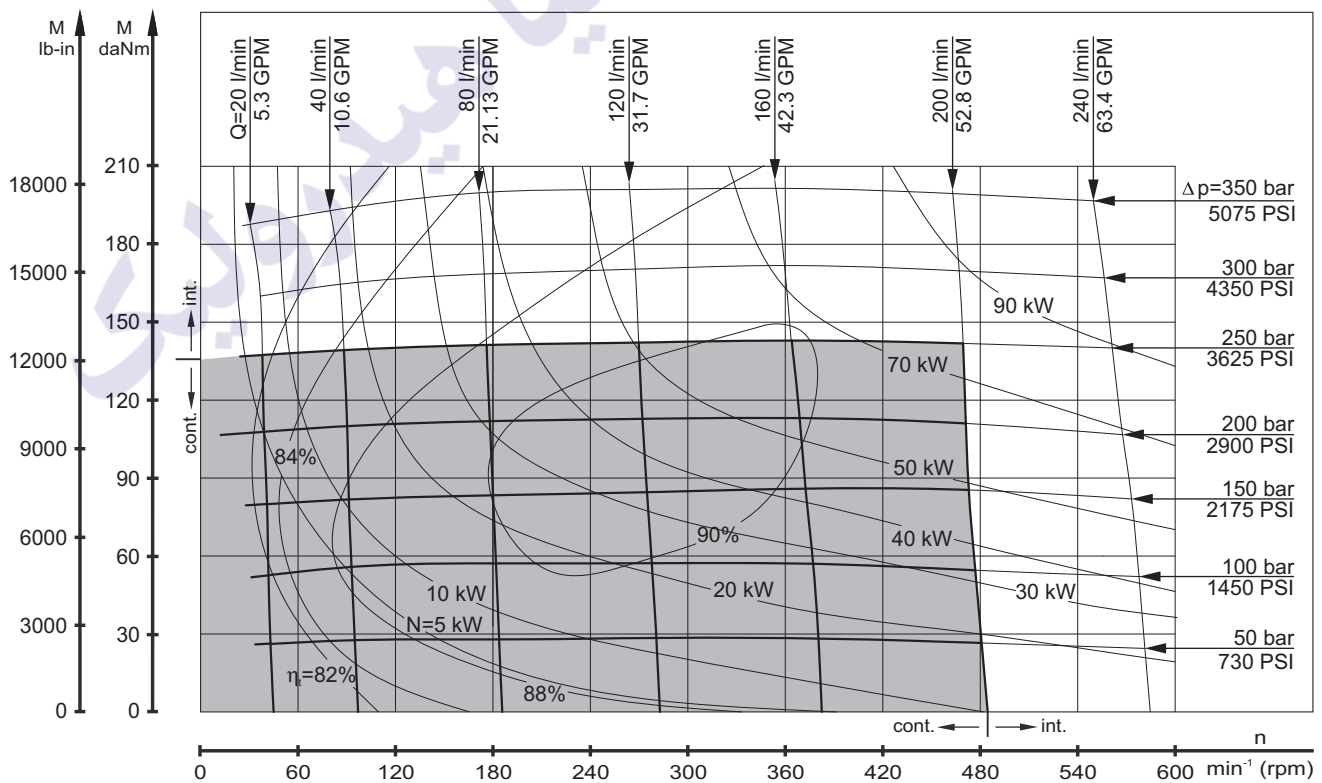

The function diagrams data was collected at back pressure 5÷10 bar [72.5÷145 PSI] and oil with viscosity of 32 mm²/s [150 SUS] at 50° C [122°F].

FUNCTION DIAGRAMS

MVM 500

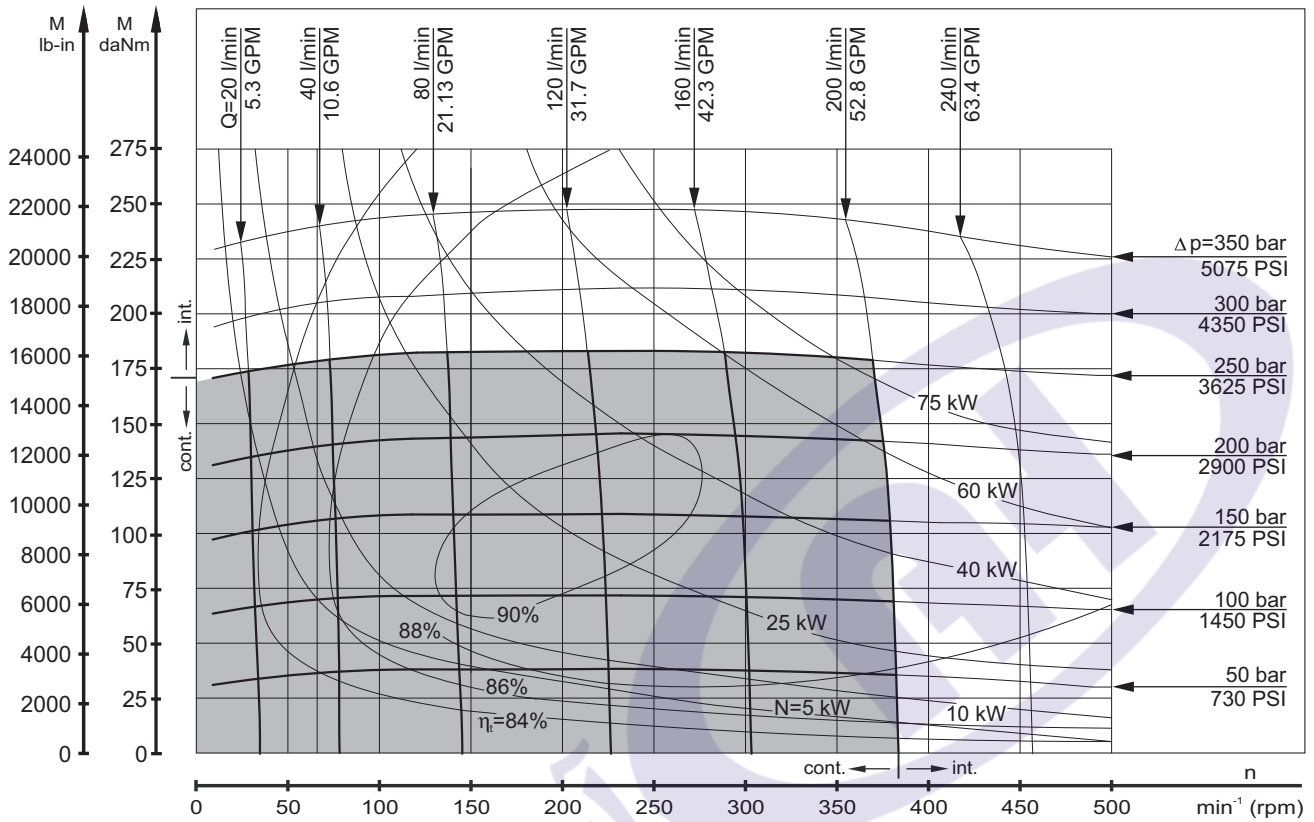

MVM 630

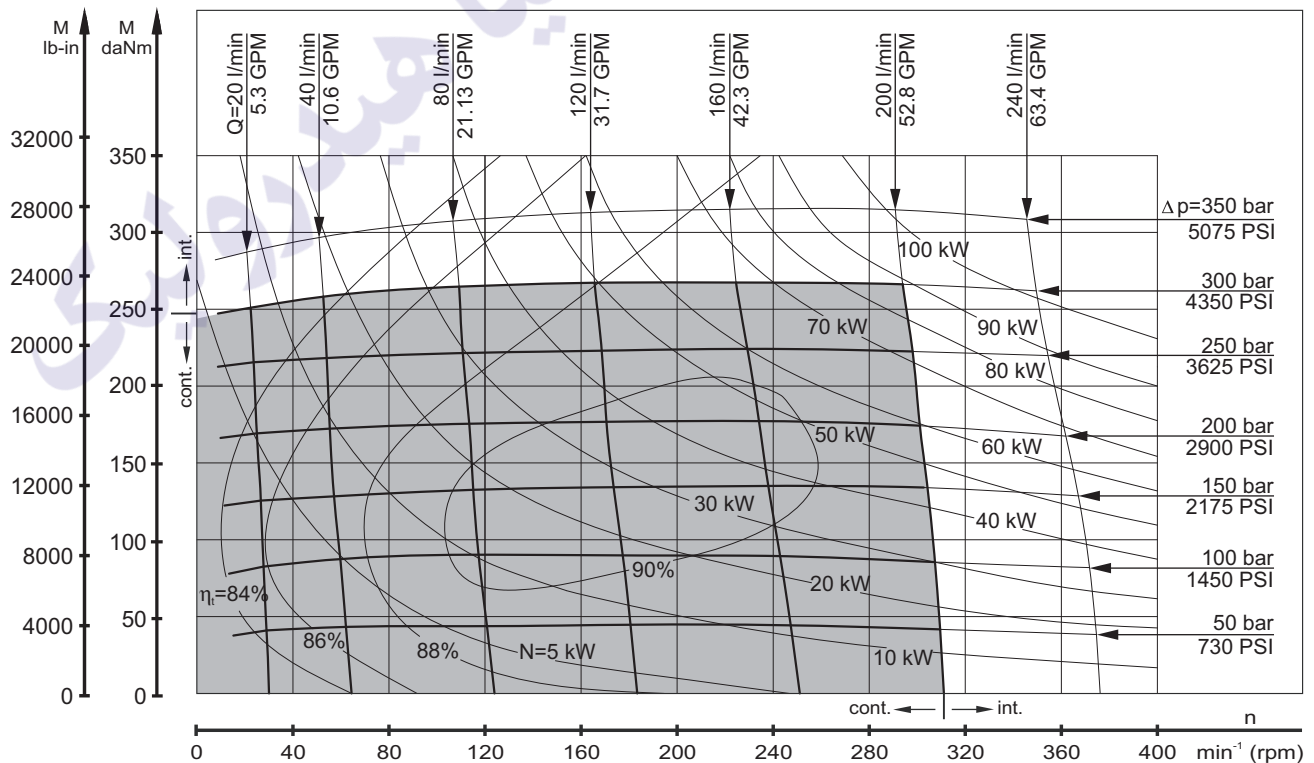

The function diagrams data was collected at back pressure 5÷10 bar [72.5÷145 PSI] and oil with viscosity of 32 mm²/s [150 SUS] at 50° C [122°F].

FUNCTION DIAGRAMS

MVM 800

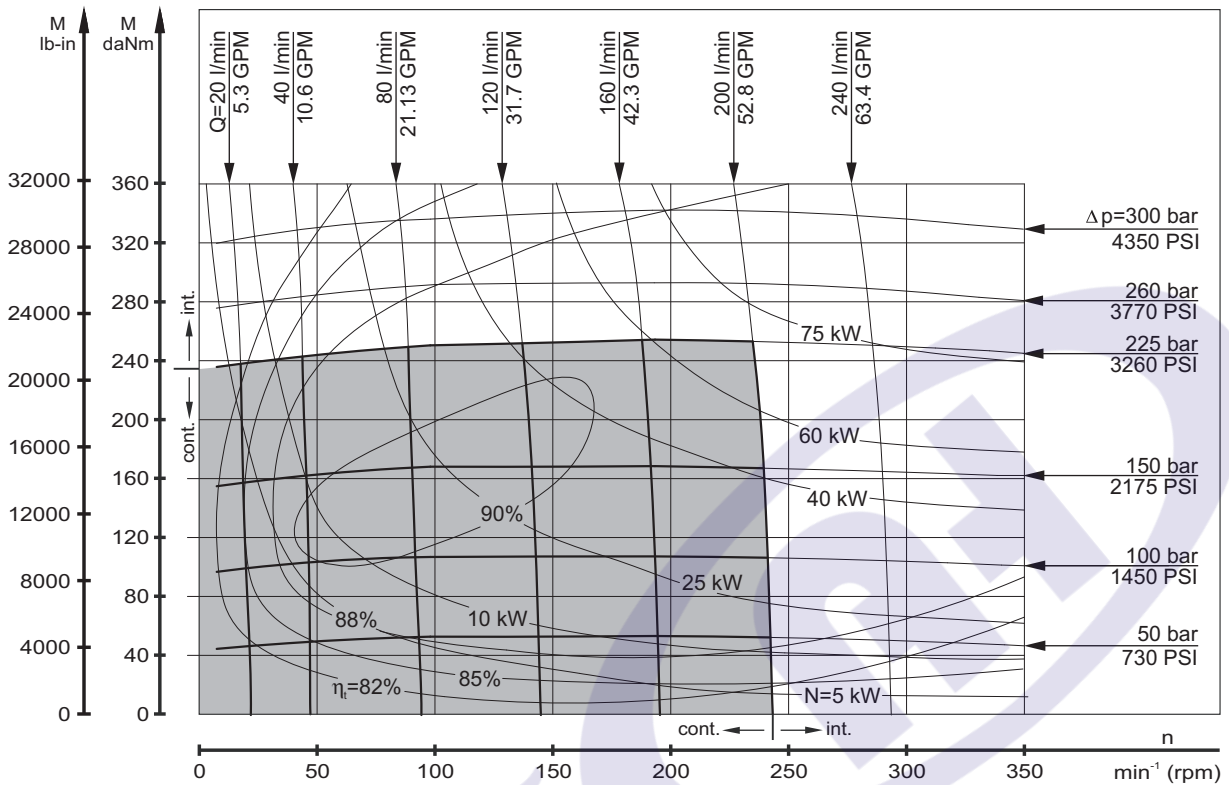

The function diagrams data was collected at back pressure 5÷10 bar [72.5÷145 PSI] and oil with viscosity of 32 mm²/s [150 SUS] at 50° C [122°F].

PERMISSIBLE SHAFT LOADS

The output shaft runs in tapered bearings that permit high axial and radial forces. Curve "1" shows max. radial shaft load. Any shaft load exceeding the values shown by the curve will seriously reduce motor life. The two other curves apply to a B10 bearing life of 3000 hours at 200 RPM.

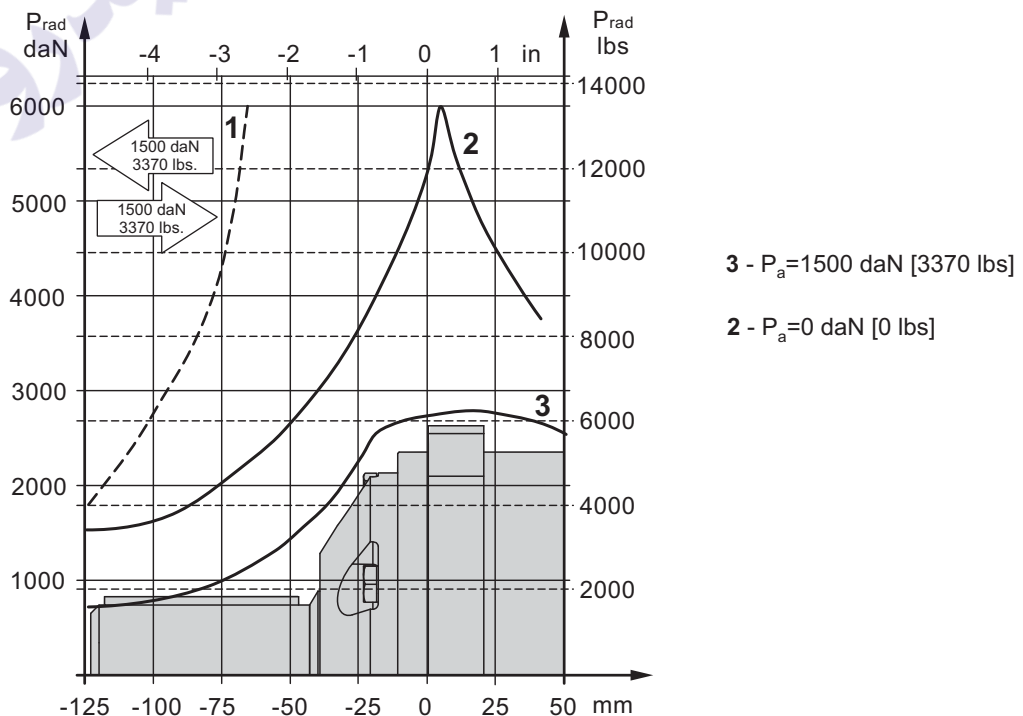

DIMENSIONS AND MOUNTING DATA MVM and MVMC

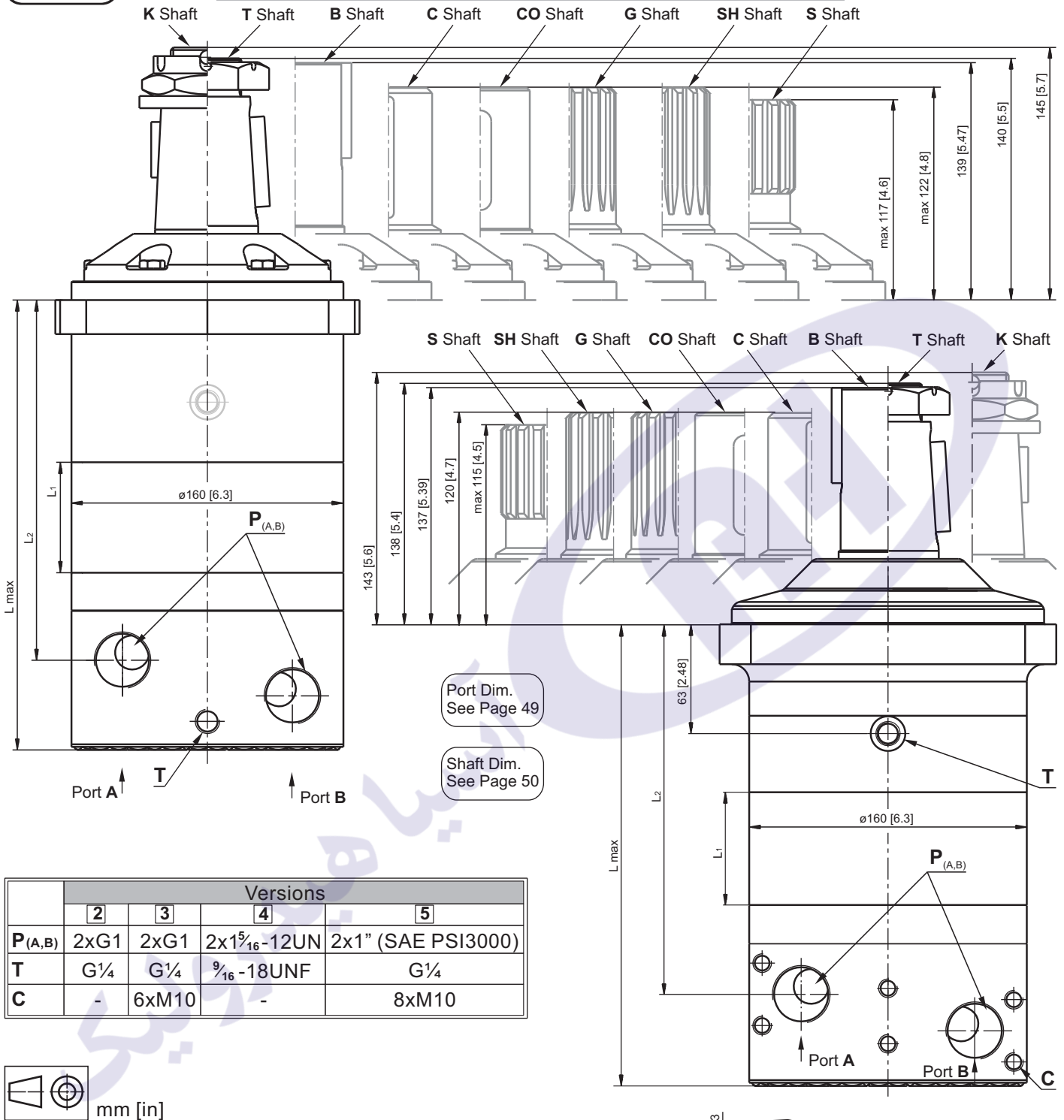

	Versions			
	2	3	4	5
P_(A,B)	2xG1	2xG1	2x1 ⁵ / ₁₆ -12UN	2x1" (SAE PSI3000)
T	G ¹ / ₄	G ¹ / ₄	9 ¹⁶ / ₁₆ -18UNF	G ¹ / ₄
C	-	6xM10	-	8xM10



Standard Rotation

Viewed from Shaft End
Port A Pressurized - **CW**
Port B Pressurized - **CCW**

Reverse Rotation

Viewed from Shaft End
Port A Pressurized - **CCW**
Port B Pressurized - **CW**

Warning: Drain line should always be used (if no check valves)!

Type	Lmax, mm [in]	L2, mm [in]	L3, mm [in]	Type	Lmax, mm [in]	L2, mm [in]	L3, mm [in]	L1, mm [in]
MVM 315	226,5 [8.92]	172,5 [6.79]	157,4 [6.20]	MVMC 315	227,5 [8.957]	173,8 [6.84]	158,7 [6.25]	25,5 [1.00]
MVM 400	233,5 [9.19]	179,5 [7.07]	164,4 [6.47]	MVMC 400	234,5 [9.232]	180,8 [7.12]	165,7 [6.52]	32,5 [1.28]
MVM 500	241,5 [9.51]	187,5 [7.38]	172,4 [6.79]	MVMC 500	242,5 [9.547]	188,8 [7.43]	173,7 [6.84]	40,5 [1.59]
MVM 630	252,0 [9.92]	198,0 [7.79]	182,9 [7.20]	MVMC 630	253,0 [9.961]	199,3 [7.85]	184,2 [7.25]	51,0 [2.01]
MVM 800	266,0 [10.47]	212,0 [8.35]	196,9 [7.75]	MVMC 800	267,0 [10.518]	213,3 [8.39]	198,2 [7.80]	65,0 [2.56]

MOUNTING

Square Mount (4 Holes)

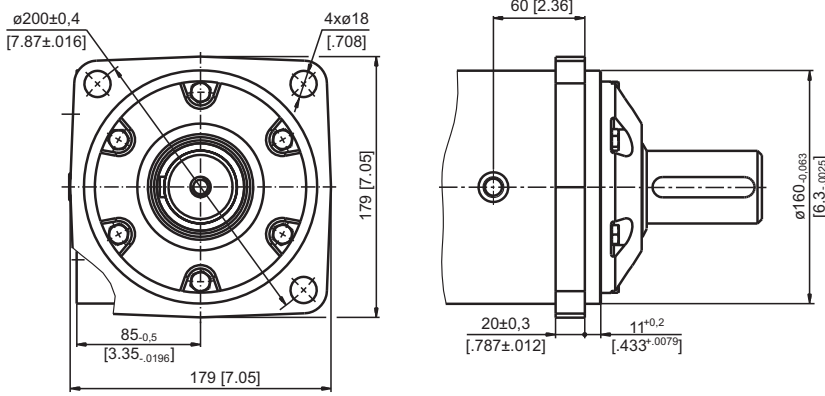

C Square Mount (four holes)

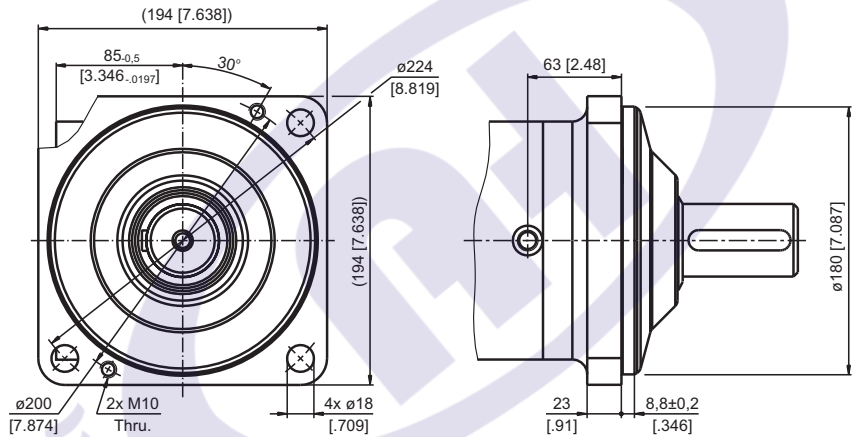

PORTS

Side Ports

Versions **2** **4**

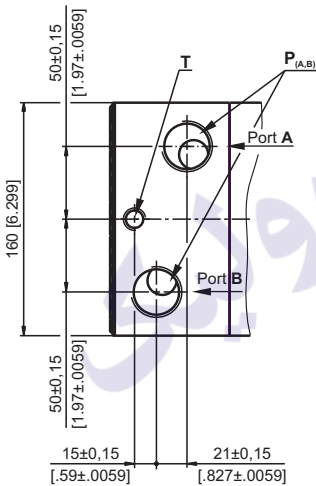

Versions **3**

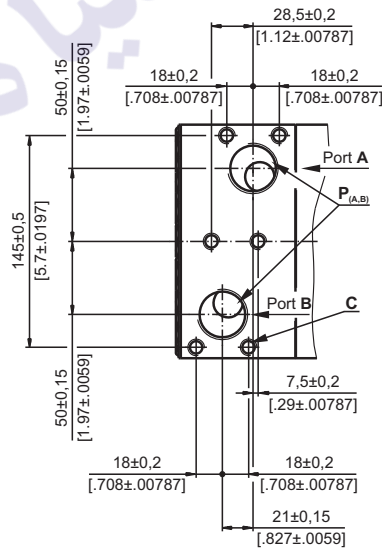

Versions **5**

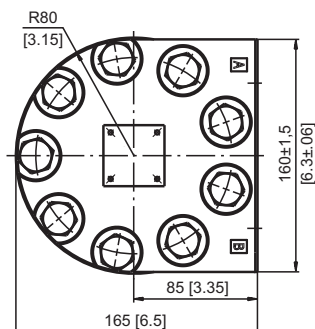
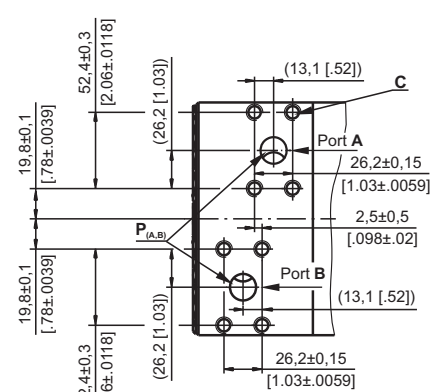

Standard Rotation

Viewed from Shaft End
Port A Pressurized - CW
Port B Pressurized - CCW

Reverse Rotation

Viewed from Shaft End
Port A Pressurized - CCW
Port B Pressurized - CW

	Versions			
	2	3	4	5
P(A,B)	2xG1	2xG1	2x1 ⁵ / ₁₆ -12UN	2x1" (SAE PSI3000)
T	G ¹ / ₄	G ¹ / ₄	⁹ / ₁₆ -18UNF	G ¹ / ₄
C	-	6xM10	-	8xM10

SHAFT EXTENSIONS

C - $\phi 50$ straight, Parallel key A14x9x70 DIN 6885

CO - $\phi 2\frac{1}{4}$ " [57,15] straight
Parallel key $\frac{1}{2}$ "x $\frac{1}{2}$ "x $2\frac{1}{4}$ " BS46

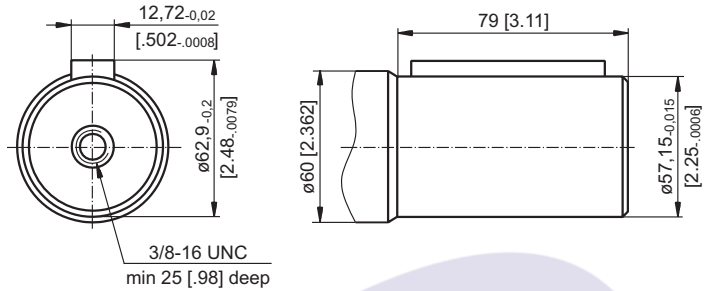
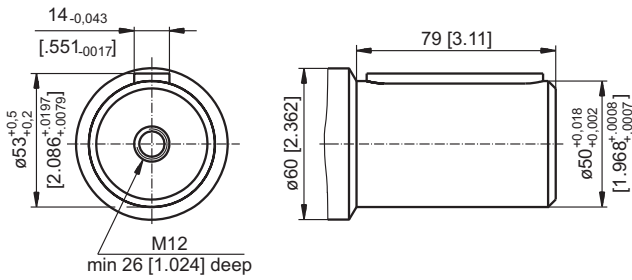

SH - $\phi 2\frac{1}{8}$ " ($\phi 53,975$) splined
16 DP 8/16 ANS B92.1-1976

B - $\phi 2\frac{1}{4}$ " [57,15] straight
Parallel key $\frac{1}{2}$ "x $\frac{1}{2}$ "x $2\frac{1}{4}$ " BS46

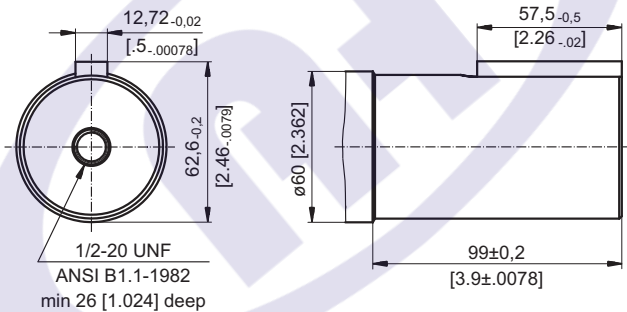
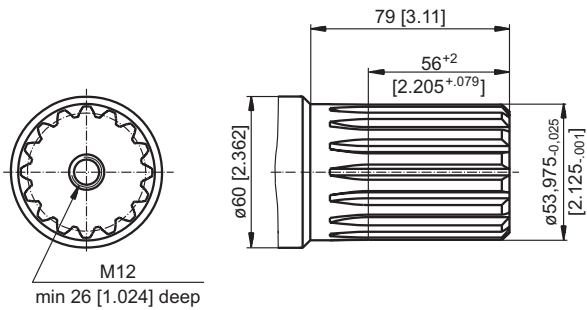

G - $\phi 2\frac{1}{8}$ " [53,975] splined
16 DP 8/16 ANS B92.1-1976

K - $\phi 60$, tapered 1:10
Parallel key B16x10x32 DIN 6885

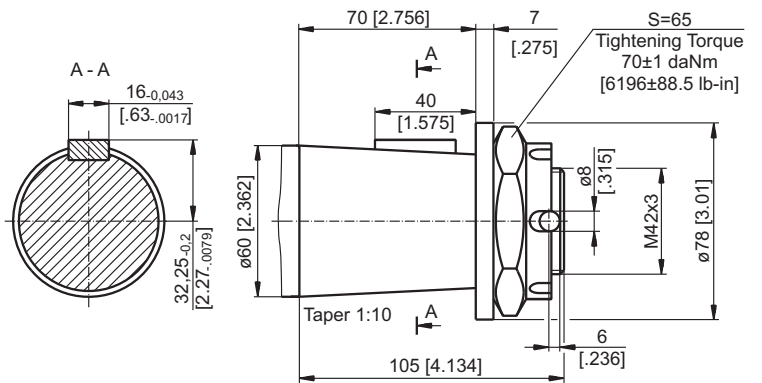
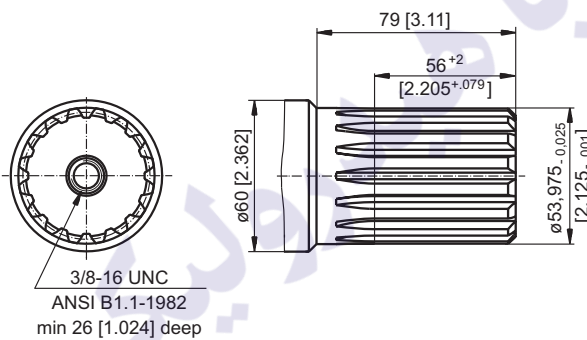

S - $\phi 2\frac{1}{8}$ " [53,975] splined
16 DP 8/16 ANS B92.1-1976

T - $\phi 2\frac{1}{4}$ " [57,15] SAE J501, tapered 1:8
key $\frac{9}{16}$ "x $\frac{9}{16}$ "x2" BS46

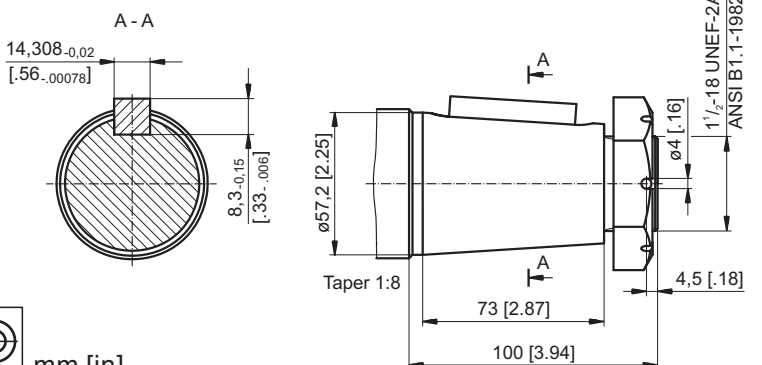
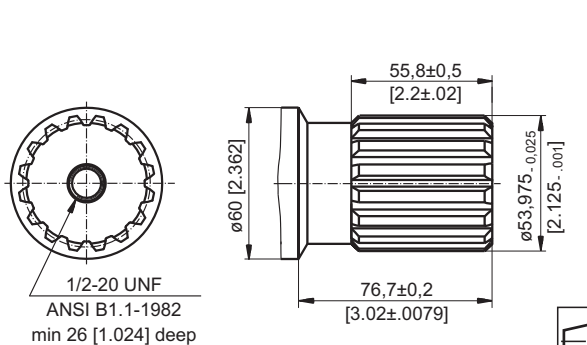

MAX. PERMISSIBLE SHAFT SEAL PRESSURE

**Max. return pressure without drain line or
max. pressure in the drain line**

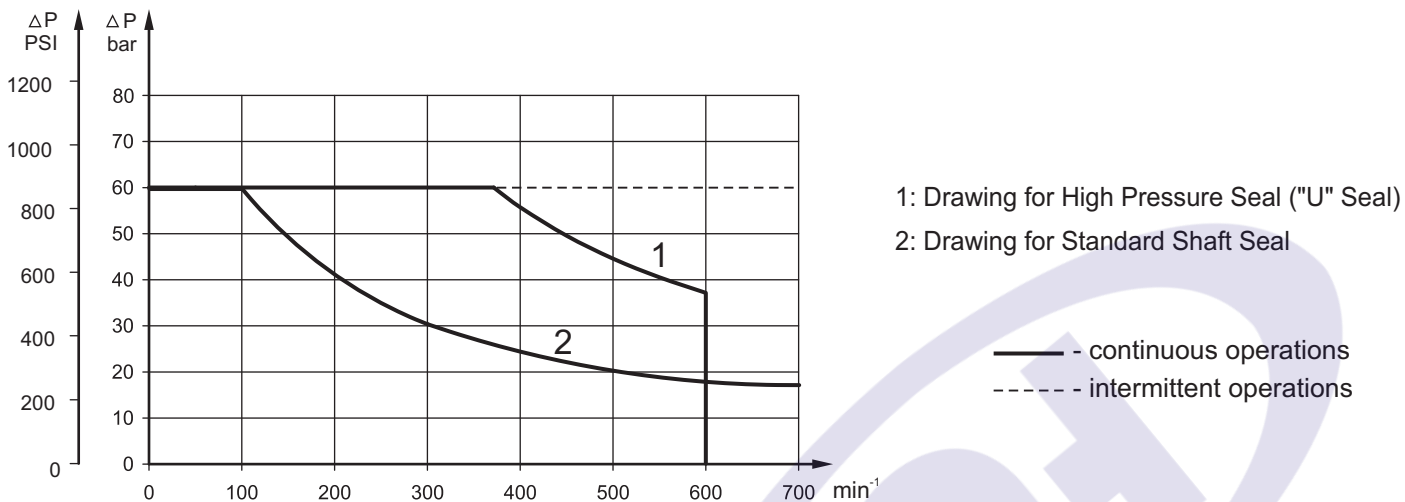

1: Drawing for High Pressure Seal ("U" Seal)
2: Drawing for Standard Shaft Seal

— - continuous operations
- - - - intermittent operations

ORDER CODE

	1	2	3	4	5	6	7	8
M V M							HD	

Pos.1 - Mounting Flange

omit - Standard square mount, four holes

C - Square mount, four holes

Pos.2 - Displacement code

315 - 314,5 cm³/rev [19.80 in³/rev]

400 - 400,9 cm³/rev [24.45 in³/rev]

500 - 499,6 cm³/rev [30.48 in³/rev]

630 - 629,1 cm³/rev [38.38 in³/rev]

800 - 801,8 cm³/rev [48.91 in³/rev]

Pos.3 - Shaft Extensions*

C - ø50 straight, Parallel key A14x9x70 DIN6885

CO - ø2¼" [57,15] straight, Parallel key ½"x½"x2¼" BS46

B - ø2¼" [57,15] straight, Parallel key ½"x½"x2¼" BS46

SH - ø2⅜" [53,975] splined, 16DP 8/16 ANS B92.1-1976

G - ø2⅜" [53,975] splined, 16DP 8/16 ANS B92.1-1976

S - ø2⅜" [53,975] splined, 16DP 8/16 ANS B92.1-1976

K - ø60 tapered 1:10, Parallel key B16x10x32 DIN6885

T - ø2¼" [57,15] SAE J501, tapered 1:8,

key 9/16"x9/16"x2" BS46

Pos.4 - Ports

2 - side ports 2xG1, G1/4, BSP thread, ISO 228

3 - side ports 2xG1, G1/4, BSP thread, ISO 228, 6xM10

4 - side ports 2x1 5/16-12 UN, O-ring, 9/16-18 UNF

5 - side ports 2x1" (SAE PSI3000), G1/4, BSP thread, SO 228, 8xM10

Pos.5 - Check Valves

omit - without check valves

1 - with check valves

Pos.6 - Shaft Seal Version (see page 50)

omit - Low pressure shaft seal

U - High pressure shaft seal

Pos.7 - Special Features

HD - Reinforced motor HD**

For Other **Special Features** see page 58

Pos.8 - Design Series

omit - Factory specified

NOTES:

* The permissible output torque for shafts must not be exceeded!

** Drain line should always be used (if no check valves).

The hydraulic motors are mangano-phosphatized as standard.