

HYDRAULIC MOTORS RW

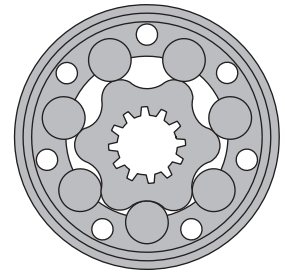

APPLICATION

- » Conveyors
- » Feeding mechanism of robots and manipulators
- » Metal working machines
- » Textile machines
- » Agricultural machines
- » Food industries
- » Grass cutting machinery etc.



CONTENTS

Specification data 84
 Function diagrams85+89
 Dimensions and mounting 90
 Permissible shaft Seal Pressure ... 91
 Permissible shaft loads 91
 Shaft extensions 92
 Order code 92

OPTIONS

- » Model - Spool valve, roll-gerotor
- » Wheel mount
- » Shafts - straight and tapered
- » Shaft seal for high and low pressure
- » Metric and BSPP ports
- » Other special features

GENERAL

Max. Displacement, cm ³ /rev [in ³ /rev]	397 [24.4]
Max. Speed, [RPM]	1029
Max. Torque, daNm [lb-in]	cont.: 61 [5400] int.: 69 [6100]
Max. Output, kW [HP]	15 [20.1]
Max. Pressure Drop, bar [PSI]	cont.: 175 [2540] int.: 200 [2900]
Max. Oil Flow, lpm [GPM]	90 [23.8]
Min. Speed, [RPM]	10
Pressure fluid	Mineral based- HLP(DIN 51524) or HM(ISO 6743/4)
Temperature range, °C [°F]	-40÷140 [-40÷284]
Optimal Viscosity range, mm ² /s [SUS]	20÷75 [98÷347]
Filtration	ISO code 20/16 (Min. recommended fluid filtration of 25 microns)

Oil flow in drain line

Pressure drop bar [PSI]	Viscosity mm ² /s [SUS]	Oil flow in drain line lpm [GPM]
100 [1450]	20 [98]	2,5 [.660]
	35 [164]	1,8 [.476]
140 [2030]	20 [98]	3,5 [.925]
	35 [164]	2,8 [.740]

Pressure Losses

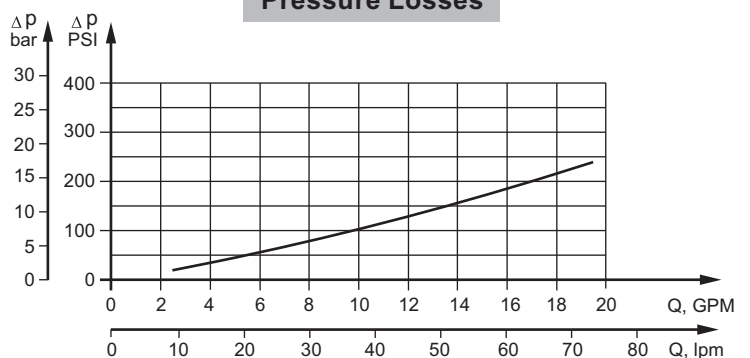

SPECIFICATION DATA

Type	RW 50	RW 80	RW 100	RW 125	RW 160	RW 200	RW 250	RW 315	RW 400	
Displacement, cm³/rev [in ³ /rev]	51,5 [3.14]	80,3 [4.90]	99,8 [6.09]	125,7 [7.67]	159,6 [9.74]	199,8 [12.19]	250,1 [15.26]	315,7 [19.26]	397 [24.4]	
Max. Speed, [RPM]	Cont.	775	750	600	475	375	300	300	240	190
	Int.*	1029	940	750	600	470	375	360	285	226
Max. Torque daNm [lb-in]	Cont.	10 [900]	20 [1770]	24 [2125]	30 [2655]	39 [3450]	45 [4000]	54 [4780]	55 [4870]	61 [5400]
	Int.*	13 [1150]	22 [1947]	28 [2480]	34 [3010]	43 [3805]	50 [4425]	61 [5400]	69 [6100]	69 [6100]
	Peak**	17 [1505]	27 [2390]	32 [2832]	37 [3275]	46 [4070]	56 [4960]	71 [6280]	84 [7430]	87 [7700]
Max. Output kW [HP]	Cont.	7 [9.5]	12,5 [17]	13 [17.4]	12,5 [16.8]	11,5 [15.4]	11 [14.8]	10 [13.4]	9 [12]	7,8 [10.5]
	Int.*	8,5 [11.9]	15 [20.1]	15 [20.1]	14,5 [19.5]	14 [18.8]	13 [17.4]	12 [16.1]	10 [13.4]	10,6 [14.2]
Max. Pressure Drop bar [PSI]	Cont.	140 [2030]	175 [2540]	175 [2540]	175 [2540]	175 [2540]	175 [2540]	175 [2540]	135 [1960]	110 [1600]
	Int.*	175 [2540]	200 [2900]	200 [2900]	200 [2900]	200 [2900]	200 [2900]	200 [2900]	175 [2540]	140 [2030]
	Peak**	225 [3260]	225 [3260]	225 [3260]	225 [3260]	225 [3260]	225 [3260]	225 [3260]	210 [3045]	175 [2540]
Max. Oil Flow lpm [GPM]	Cont.	40 [10,6]	60 [15,9]	60 [15,9]	60 [15,9]	60 [15,9]	60 [15,9]	75 [19,8]	75 [19,8]	75 [19,8]
	Int.*	50 [13,2]	75 [19,8]	75 [19,8]	75 [19,8]	75 [19,8]	75 [19,8]	90 [23,8]	90 [23,8]	90 [23,8]
Max. Inlet Pressure bar [PSI]	Cont.	175 [2540]	175 [2540]	175 [2540]	175 [2540]	175 [2540]	175 [2540]	175 [2540]	175 [2540]	175 [2540]
	Int.*	200 [2900]	200 [2900]	200 [2900]	200 [2900]	200 [2900]	200 [2900]	200 [2900]	200 [2900]	200 [2900]
	Peak**	225 [3260]	225 [3260]	225 [3260]	225 [3260]	225 [3260]	225 [3260]	225 [3260]	225 [3260]	225 [3260]
Max. Return Pressure with Drain Line bar [PSI]	Cont.	175 [2540]	175 [2540]	175 [2540]	175 [2540]	175 [2540]	175 [2540]	175 [2540]	175 [2540]	175 [2540]
	Int.*	200 [2900]	200 [2900]	200 [2900]	200 [2900]	200 [2900]	200 [2900]	200 [2900]	200 [2900]	200 [2900]
	Peak**	225 [3260]	225 [3260]	225 [3260]	225 [3260]	225 [3260]	225 [3260]	225 [3260]	225 [3260]	225 [3260]
Max. Starting Pressure with Unloaded Shaft, bar [PSI]	10 [145]	10 [145]	10 [145]	9 [130]	7 [102]	5 [73]	5 [73]	5 [73]	5 [73]	
Min. Starting Torque daNm [lb-in]	At max.press. drop Cont.	8 [710]	15 [1330]	20 [1770]	25 [2215]	32 [2832]	41 [3630]	50 [4425]	50 [4425]	50 [4425]
	At max.press. drop Int.*	10 [885]	17 [1505]	23 [2035]	28 [2480]	37 [3275]	46 [4070]	55 [4870]	66 [5840]	61 [5400]
Min. Speed***, [RPM]	10	10	10	10	10	10	10	10	10	
Weight, kg [lb]	9,6 [21.2]	9,7 [21.4]	9,8 [21.7]	10,0 [22.1]	10,3 [22.7]	10,8 [23.8]	11,3 [24.9]	11,8 [26]	12,5 [27.63]	

* Intermittent operation: the permissible values may occur for max. 10% of every minute.

** Peak load: the permissible values may occur for max. 1% of every minute.

*** For speeds lower than given, consult factory or your regional manager.

- Intermittent speed and intermittent pressure must not occur simultaneously.
- Recommended filtration is per ISO cleanliness code 20/16. A nominal filtration of 25 micron or better.
- Recommend using a premium quality, anti-wear type mineral based hydraulic oil HLP(DIN51524) or HM (ISO 6743/4).
If using synthetic fluids consult the factory for alternative seal materials.
- Recommended minimum oil viscosity 13 mm²/s [70 SUS] at 50°C [122°F].
- Recommended maximum system operating temperature is 82°C [180°F].
- To assure optimum motor life fill with fluid prior to loading and run at moderate load and speed for 10-15 minutes.

FUNCTION DIAGRAMS

RW 50

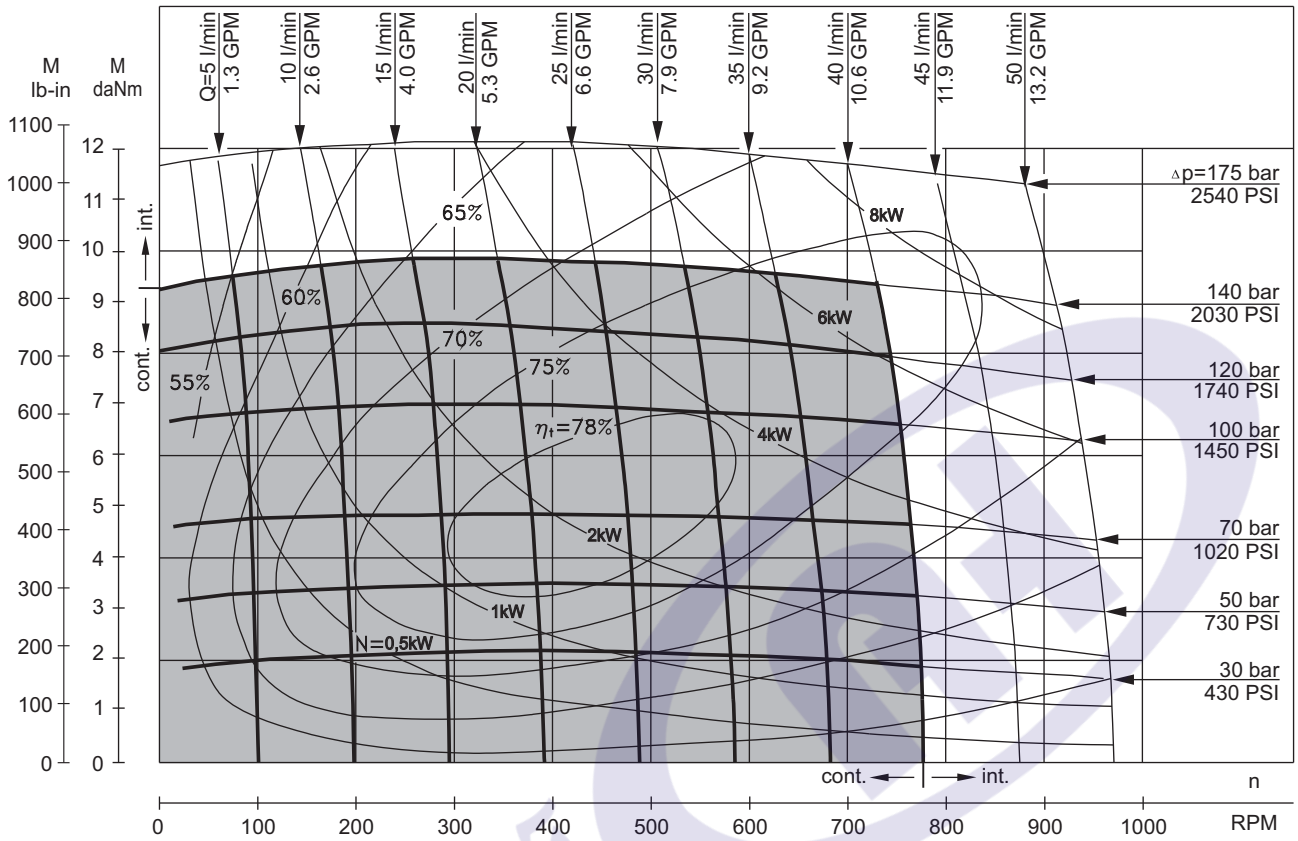

RW 80

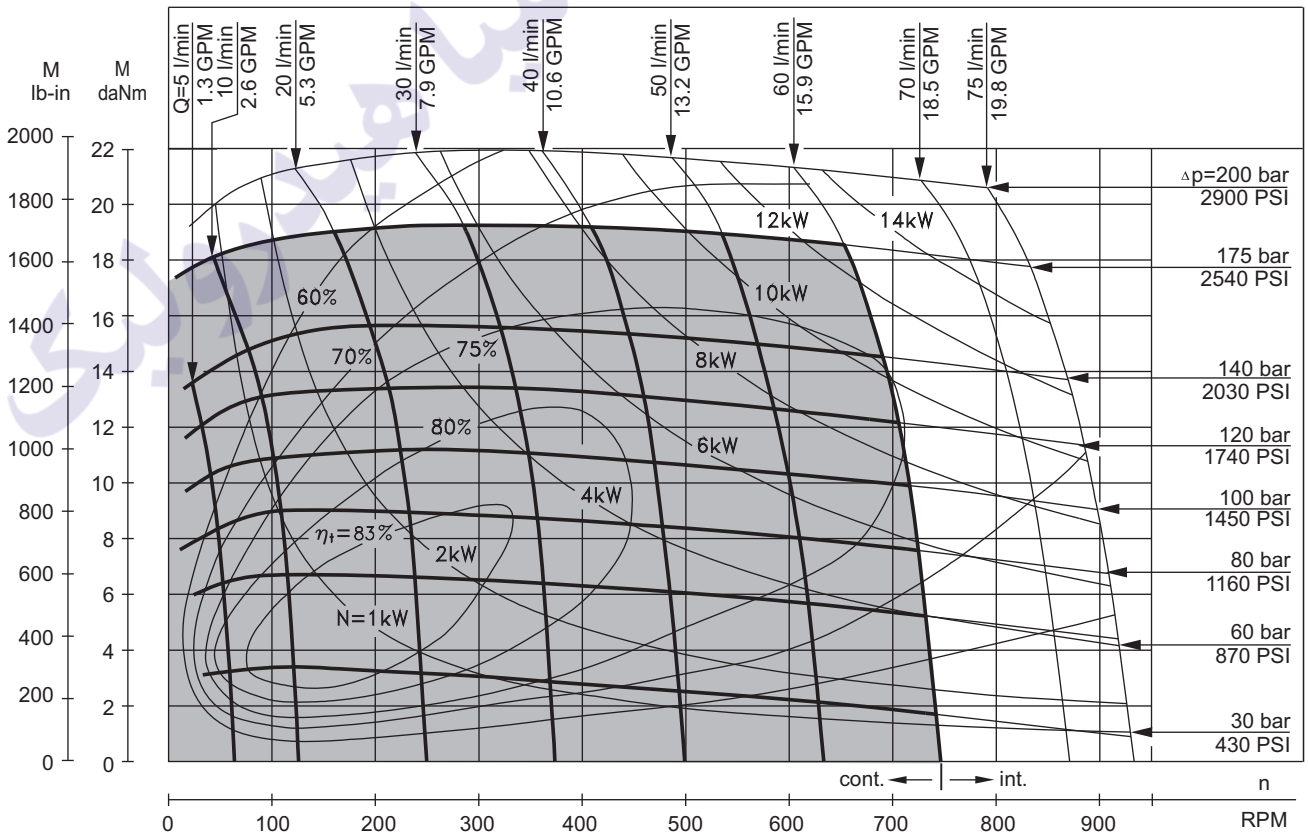

The function diagrams data is for average performance of randomly selected motors at back pressure $5 \pm 10 \text{ bar}$ [72.5 \pm 145 PSI] and oil with viscosity of $32 \text{ mm}^2/\text{s}$ [150 SUS] at 50°C [122°F].

FUNCTION DIAGRAMS

RW 100

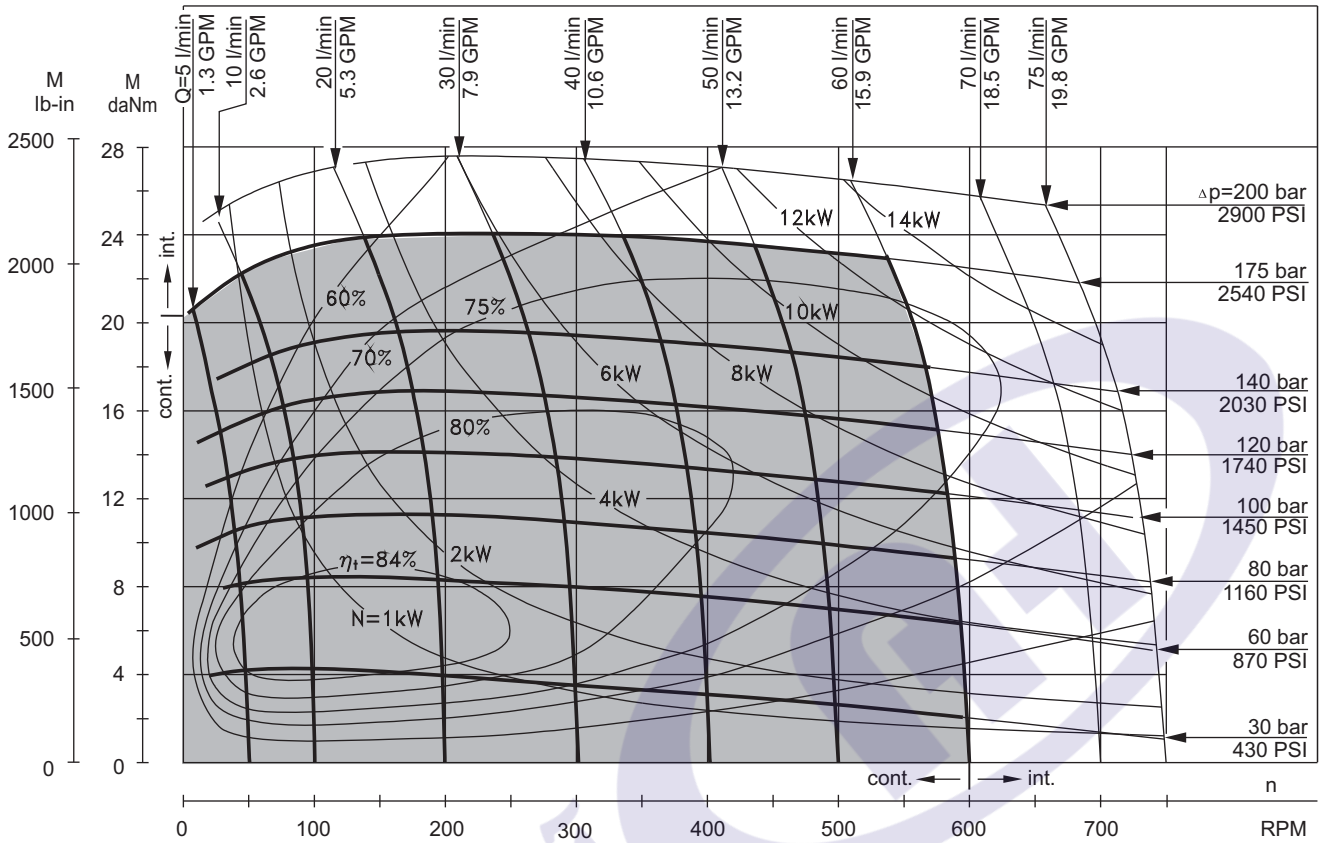

RW 125

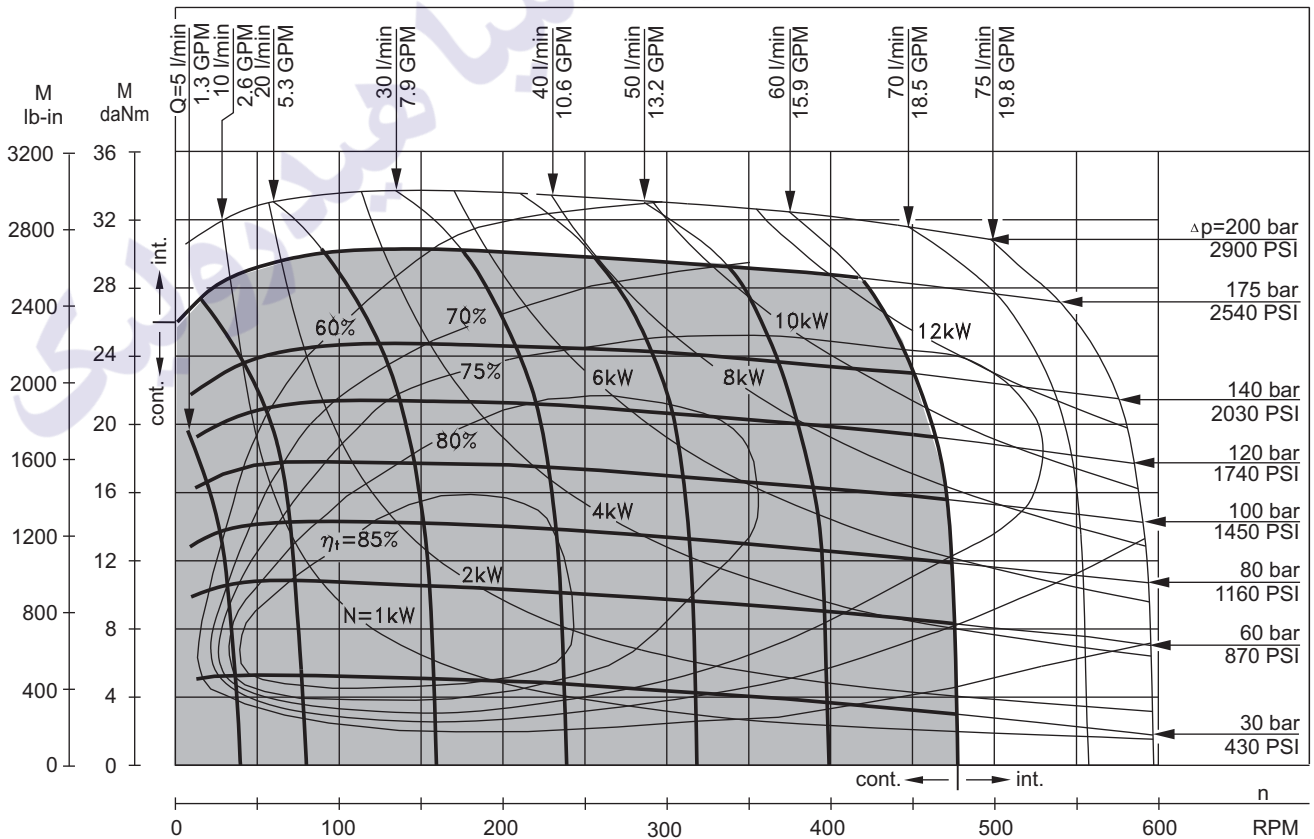

The function diagrams data is for average performance of randomly selected motors at back pressure 5 ± 10 bar [72.5 \pm 145 PSI] and oil with viscosity of 32 mm²/s [150 SUS] at 50°C [122°F].

FUNCTION DIAGRAMS

RW 160

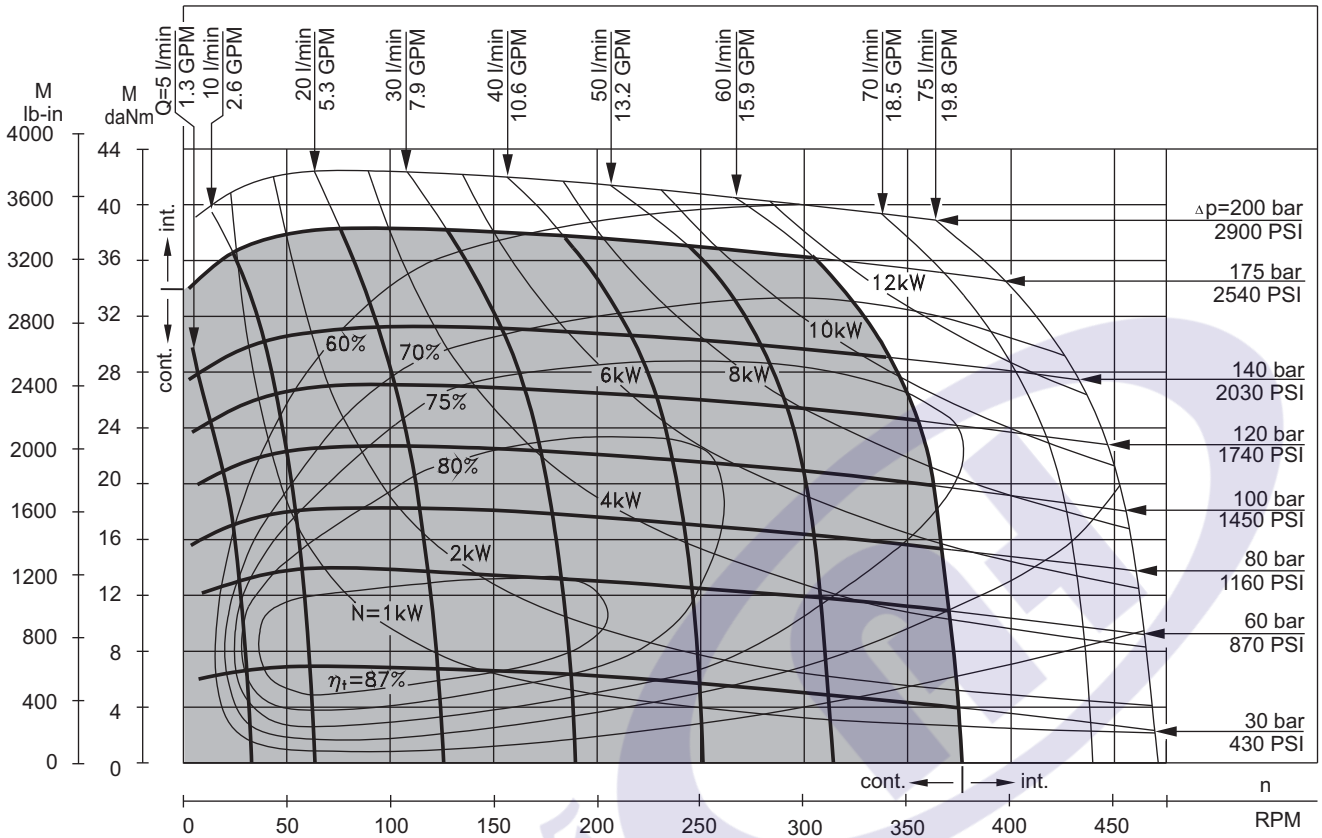

RW 200

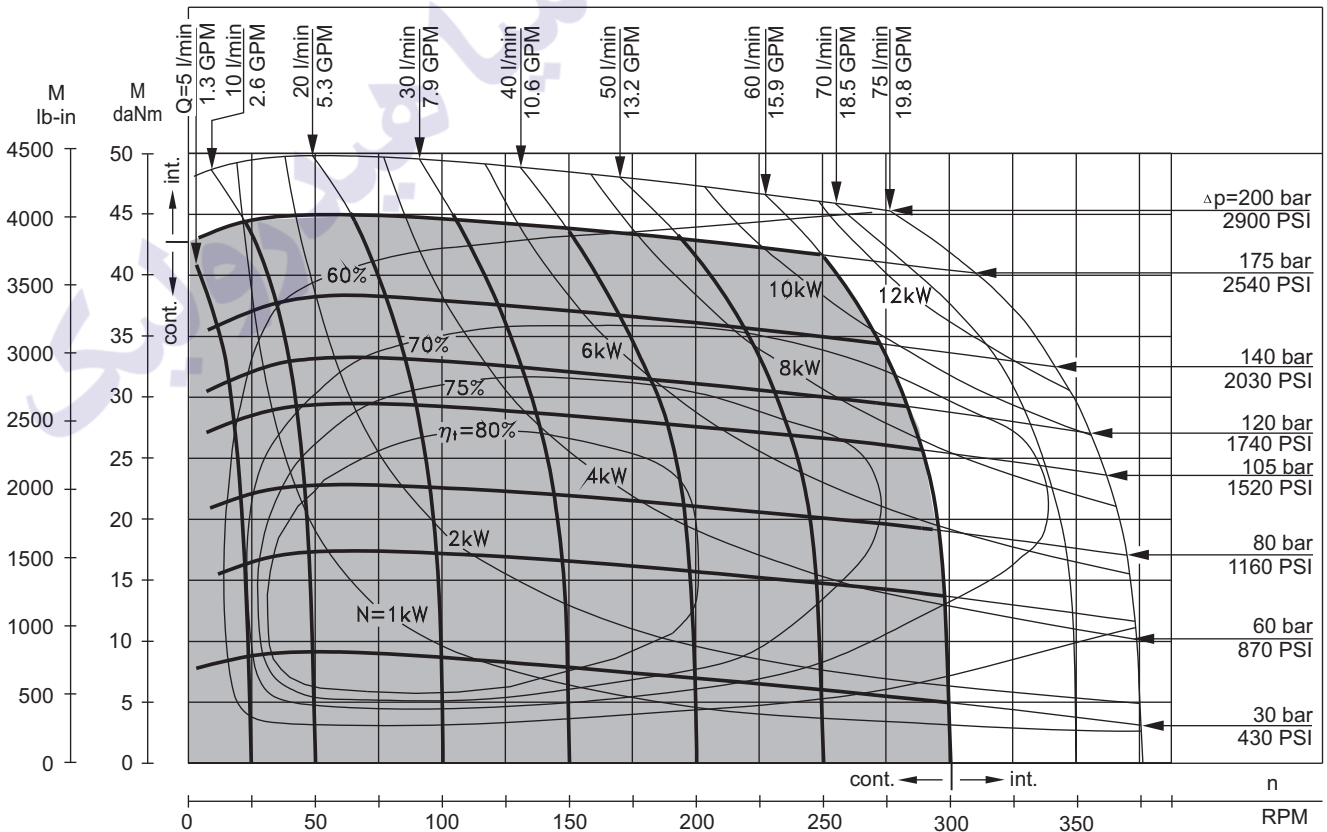

The function diagrams data is for average performance of randomly selected motors at back pressure 5 ± 10 bar [72.5 \pm 145 PSI] and oil with viscosity of 32 mm²/s [150 SUS] at 50°C [122°F].

FUNCTION DIAGRAMS

RW 250

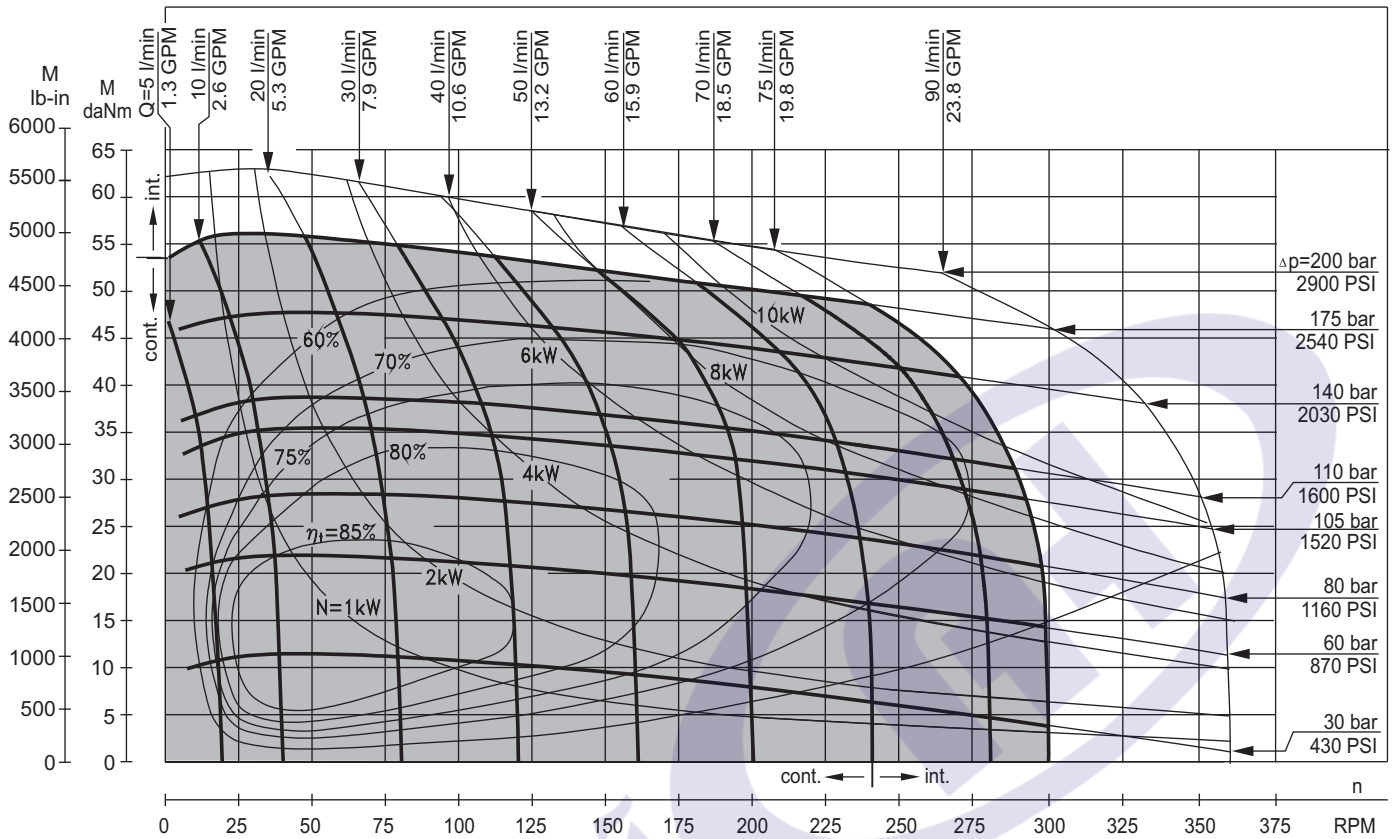

RW 315

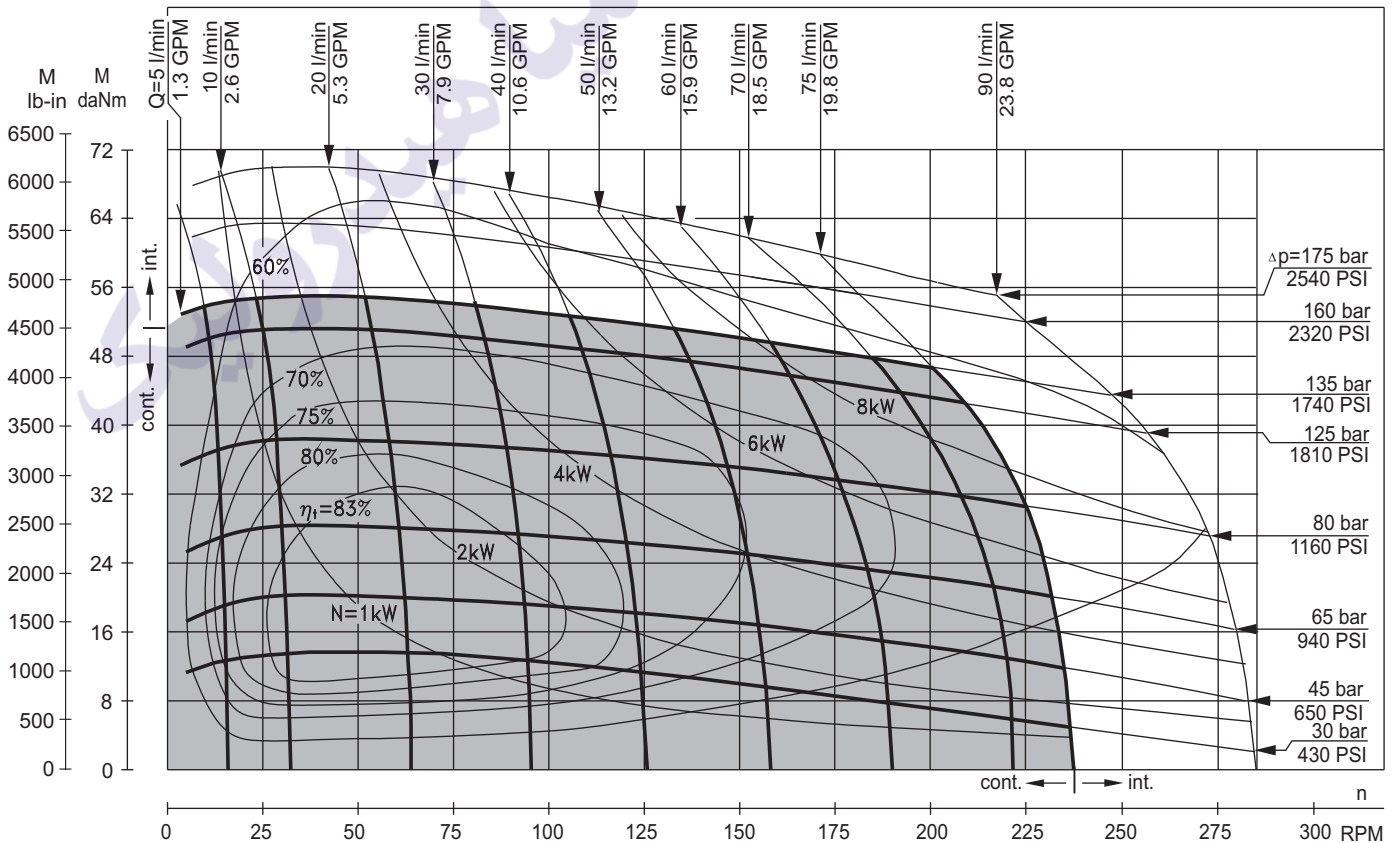

The function diagrams data is for average performance of randomly selected motors at back pressure 5 ± 10 bar [72.5 \pm 145 PSI] and oil with viscosity of 32 mm²/s [150 SUS] at 50°C [122°F].

FUNCTION DIAGRAMS

RW 400

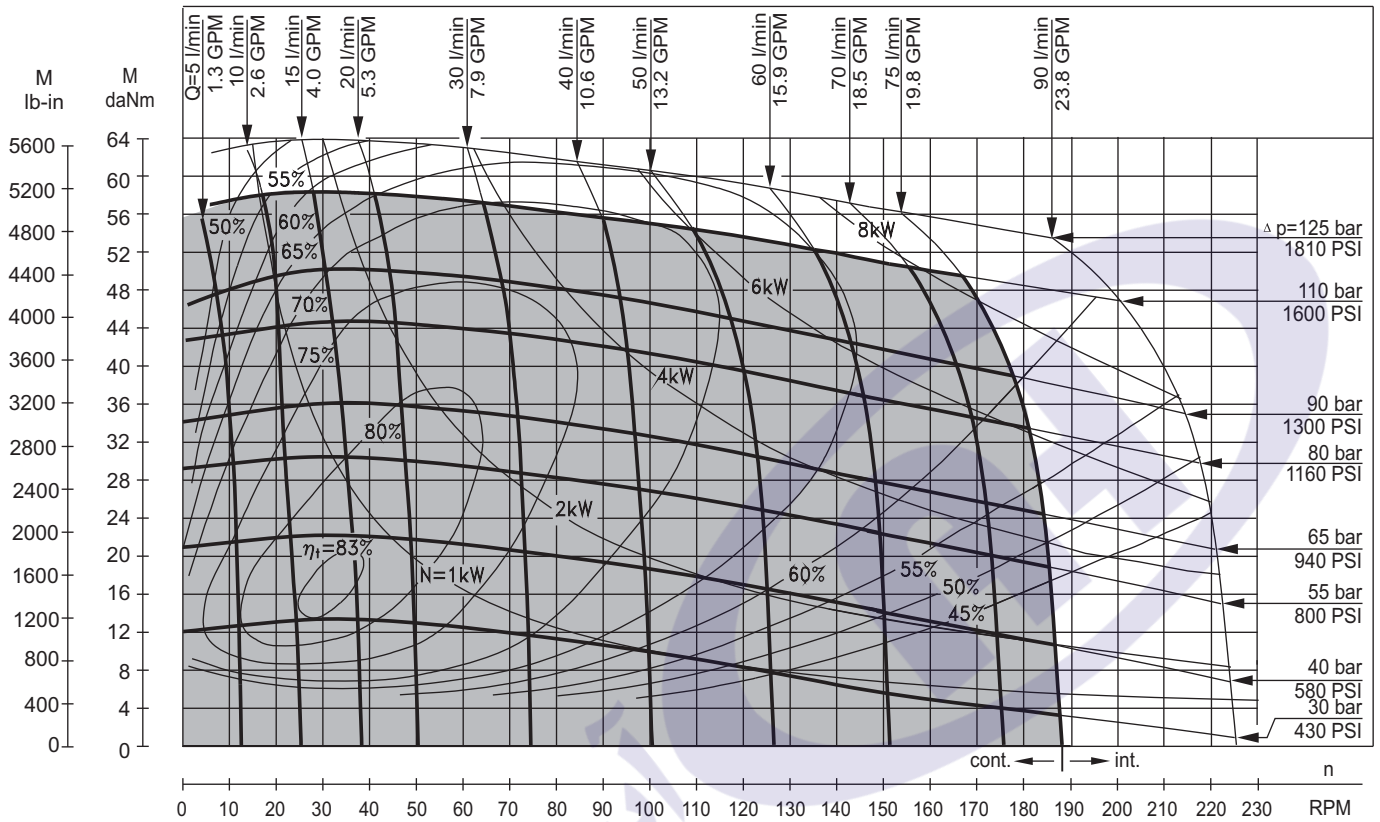

The function diagrams data is for average performance of randomly selected motors at back pressure 5±10 bar [72.5±145 PSI] and oil with viscosity of 32 mm²/s [150 SUS] at 50°C [122°F].

DIMENSIONS AND MOUNTING DATA

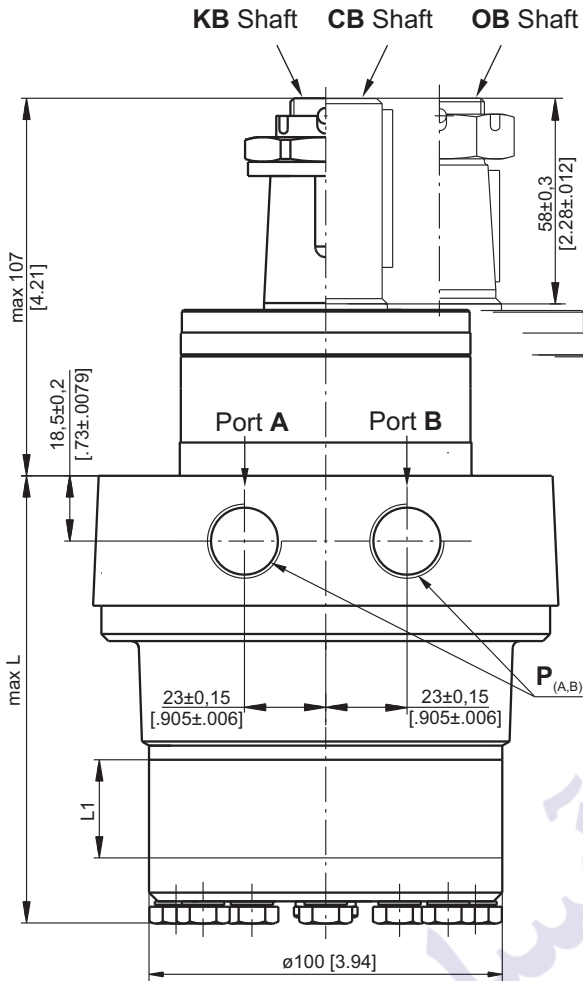

Shaft Dim.
See Page 92

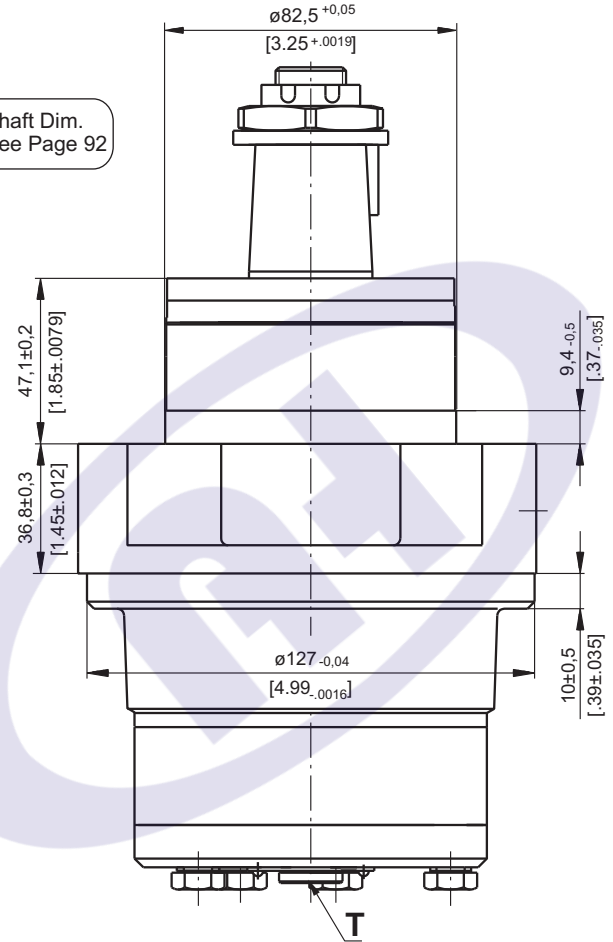

Type	L, mm [in]	L1, mm [in]
RW 50	108,0 [4.25]	9,0 [.35]
RW 80	113,0 [4.45]	14,0 [.55]
RW 100	116,5 [4.59]	17,4 [.69]
RW 125	120,5 [4.74]	21,8 [.86]
RW 160	126,5 [4.98]	27,8 [1.09]
RW 200	133,5 [5.26]	34,8 [1.37]
RW 250	142,5 [5.61]	43,5 [1.71]
RW 315	153,5 [6.04]	54,8 [2.16]
RW 400	168,5 [6.63]	69,4 [2.73]

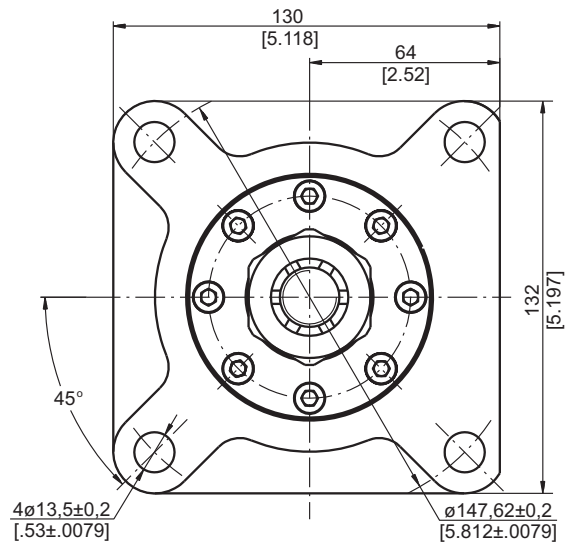

P_(A,B): 2xG1/2 or 2xM22x1,5 - 17 mm [.67 in.] depth
 T : G1/4 or M14x1,5 - 12 mm [.47 in.] depth (plugged)

Standard Rotation
 Viewed from Shaft End
 Port A Pressurized - CW
 Port B Pressurized - CCW

Reverse Rotation
 Viewed from Shaft End
 Port A Pressurized - CCW
 Port B Pressurized - CW



MAX. PERMISSIBLE SHAFT SEAL PRESSURE

RW...; RW...UK motors with drain connection:

The shaft seal pressure equals the pressure in the drain line.

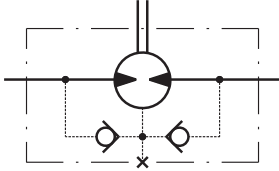

RW...1 motors without drain connection:

The shaft seal pressure never exceeds the pressure in the return line.

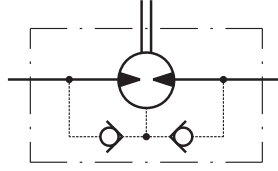

RW...U motors with high pressure seal and drain connection:

The shaft seal pressure equals the pressure in the drain line.

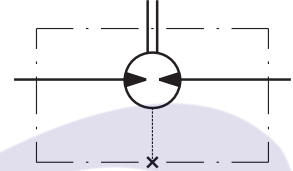

Max. return pressure without drain line or max. pressure in the drain line

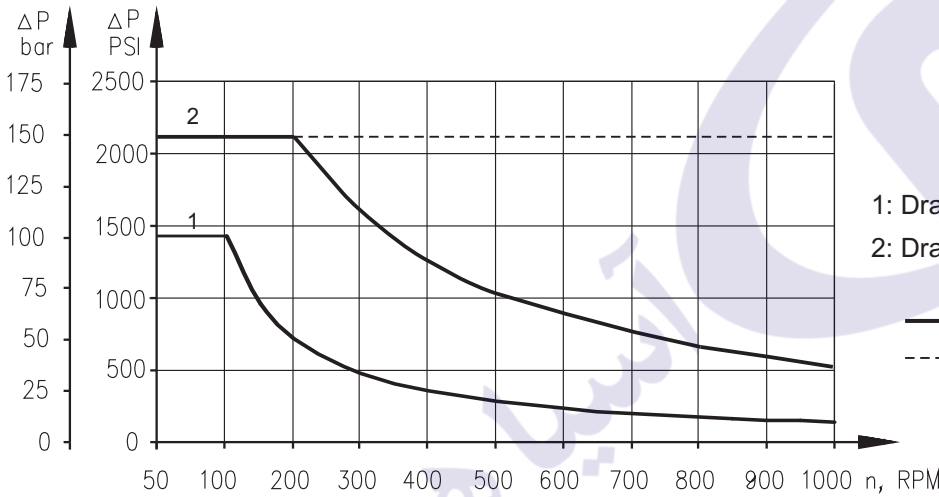

- 1: Drawing for Standard Shaft Seal
- 2: Drawing for High Pressure Seal ("U" Seal)
- - continuous operations
- - - - intermittent operations

PERMISSIBLE SHAFT LOADS

The curve applies to a B10 bearing life of 2000 hours.

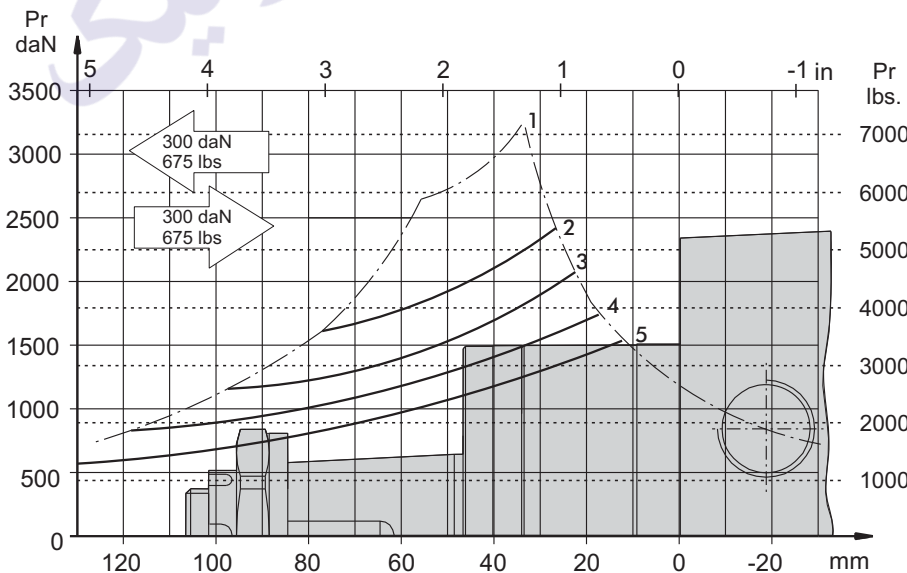

- 1. Permissible radial shaft load
- 2. Drawing by n= 50 rpm
- 3. Drawing by n=100 rpm
- 4. Drawing by n=200 rpm
- 5. Drawing by n=400 rpm

SHAFT EXTENSIONS

CB - $\phi 32$ straight, Parallel key A10x8x45 DIN 6885
Max. Torque 77 daNm [6815 lb-in]

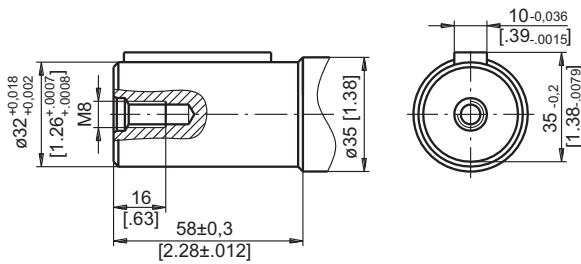

KB - tapered 1:10, Parallel key B6x6x20 DIN 6885
Max. Torque 95 daNm [8400 lb-in]

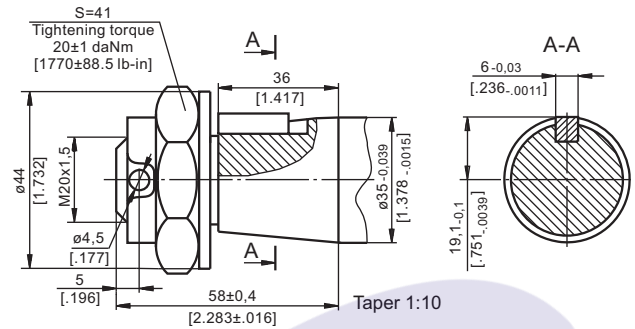

OB - tapered 1:8 SAEJ 501, Parallel key $5/16" \times 5/16" \times 1 1/4"$ BS46
Max. Torque 77 daNm [6815 lb-in]

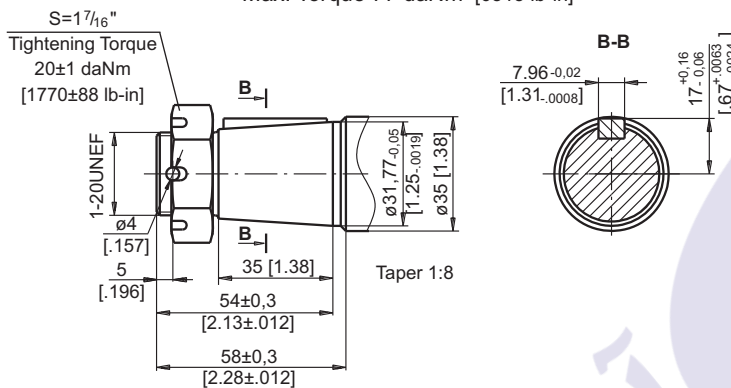

ORDER CODE

	1	2	3	4	5	6	7
RW							

Pos.1 - Displacement code	
50	- 51,5 cm ³ /rev [3.14 in ³ /rev]
80	- 80,3 cm ³ /rev [4.90 in ³ /rev]
100	- 99,8 cm ³ /rev [6.09 in ³ /rev]
125	- 125,7 cm ³ /rev [7.67 in ³ /rev]
160	- 159,6 cm ³ /rev [9.74 in ³ /rev]
200	- 199,8 cm ³ /rev [12.19 in ³ /rev]
250	- 250,1 cm ³ /rev [15.26 in ³ /rev]
315	- 315,7 cm ³ /rev [19.26 in ³ /rev]
400	- 397,0 cm ³ /rev [24.40 in ³ /rev]
Pos.2 - Shaft Extensions*	
CB	- $\phi 32$ straight, Parallel key A10x8x45 DIN6885
KB	- $\phi 35$ tapered 1:10, Parallel key B6x6x20 DIN6888
OB	- $\phi 1 1/4$ " tapered 1:8, Parallel key $5/16" \times 5/16" \times 1 1/4"$ BS46

Pos.3 - Shaft Seal Pressure	
omit	- Standard shaft seal
U	- High pressure shaft seal without check valves
UK	- High pressure shaft seal with check valve
Pos.4 - Drain Port	
omit	- with drain port
1	- without drain port
Pos.5 - Ports	
omit	- BSPP (ISO 228)
M	- Metric (ISO 262)
Pos.6 - Special Features (see page 120)	
Pos.7 - Design Series	
omit	- Factory specified

NOTE:

* The permissible output torque for shafts must not be exceeded!

The hydraulic motors are mangano-phosphatized as standard.