

HYDROSTATIC STEERING UNITS TYPE XY.../1

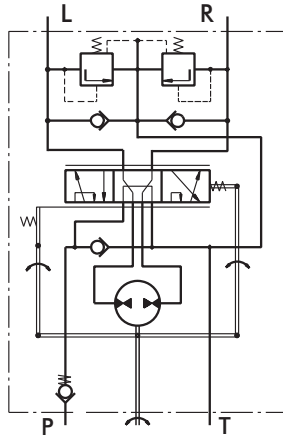

The M+S Hydraulic Hydrostatic Steering units are used in low-speed vehicles which driving speed does not exceed 60 km/h - such as: building machines, fork-lift trucks, harvesting machines, off-highway equipment and others. These hydraulic units amplify the torque to the steering wheels, with no need of hard mechanical connection.



"Open Center - Load Reaction"
XY...-0/1

The XY hydrostatic steering unit incorporates an axially displaced tracing valve and a metering pump in one housing. The working liquid is supplied by a separate pump and then is directed by the metering pump to the steering cylinders.

The XY steering unit is manufactured with a built-in check valves, and there is an option for a built-in relief valve in the inlet.

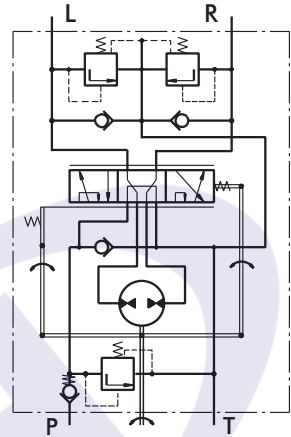

"Open Center - Load Reaction"
XY...-.../1

SPECIFICATION DATA

Parameters	Type				
	XY 85.../1	XY 120.../1	XY 145.../1		
Displacement	cm ³ /rev [in ³ /rev]	84 [5.13]	120 [7.32]	144 [8.79]	
Rated Flow*	lpm [GPM]	9 [2.4]	12 [3.2]	15 [4.0]	
Rated Pressure	bar [PSI]	150 [2175]			
Relief Valve Pressure Settings**	bar [PSI]	80 [1160]	100 [1450]	125 [1810]	150 [2175]
Shock Valves Pressure Settings***	bar [PSI]	200 [2900]			
Max. Cont. Pressure in Line T	bar [PSI]	20 [290]			
Max. Torque at Servoamplifying	Nm [lb - in]	3,5 [31]			
Max. Torque w/o Servoamplifying	Nm [lb - in]	120 [1065]			
Weight	kg [lb]	6,4 [14.1]	6,6 [14.6]	6,8 [15.0]	
Dimension A	mm [in]	136,3 [5.37]	141.5 [5.57]	144.5 [5.69]	

* Rated Flow at 100 RPM.

** Pressure Settings are at Rated Flow (as in the table) and viscosity 21 mm²/s [105 SUS] at 50° C [122°F].

***Pressure Settings are at flow rate of 4 lpm [1.06 GPM] and viscosity 21 mm²/s [105 SUS] at 50° C [122°F].

DIMENSIONS AND MOUNTING DATA

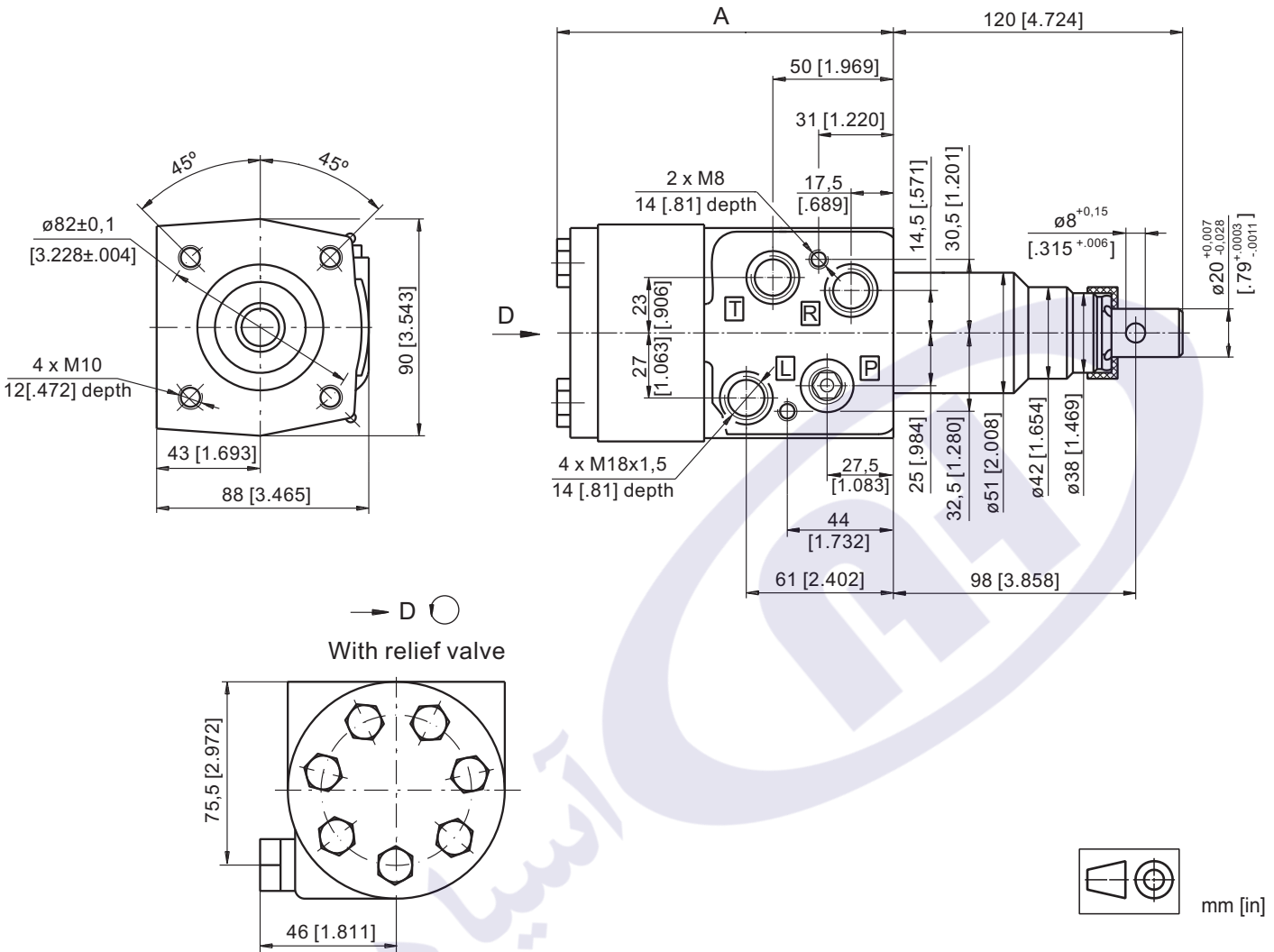

ORDER CODE

1	2	3	4	5
XY	-	/	1	

Pos.1 - Displacement code

85	- 84,0 cm ³ /rev [5.13 in ³ /rev]
120	- 120,0 cm ³ /rev [7.32 in ³ /rev]
145	- 144,0 cm ³ /rev [8.79 in ³ /rev]

Pos.2 - Relief Valve Pressure Settings

8	- 80 bar [1160 PSI]
10	- 100 bar [1450 PSI]
12,5	- 125 bar [1810 PSI]
15	- 150 bar [2175 PSI]
0	- without Relief Valve

Pos.3 - Versions

1	- Version 1 "Open Center - Load Reaction"
----------	---

Pos.4 - Option (Paint)*

omit	- No Paint
P	- Painted
PC	- Corrosion Protected Paint
PS	- Special Paint**
PCS	- Special Corrosion Protected Paint**

Pos.5 - Design Series

omit	- Factory specified
------	---------------------

NOTES:

- * Colour at customer's request.
- ** Non painted feeding surfaces, colour at customer's request.

The steering units are mangano-phosphatized as standard.